

# Verzoek tot Wijziging



wij bouwen aan de



Algemeen	
<b>Project:</b>	Tramvervoersysteem Uithoflijn
<b>Initiatiefnemer:</b>	Provincie Utrecht - afdeling OV
<b>VTW nr.:</b>	OG-VTW-166.1
<b>VTW nr (extern):</b>	
<b>Werknaam:</b>	DRIS halte UCC (ontwerp)
<b>Inhoudelijk behandelaar OG</b>	
<b>Inhoudelijk behandelaar ON</b>	
<b>Status</b>	definitief
<b>Type wijziging</b>	wijziging t.o.v. contract
<b>Tracédeel</b>	Tracédeel Stationsgebied (OVT + D)

Betreft contractartikel		
Kenmerk	Titel	Titel/nr/pagina

Aanleiding en oorzaak (korte omschrijving van proces en wijziging)
<p>Het dynamisch reizigersinformatiesysteem (DRIS) maakt onderdeel uit van het integrale vervoersysteem voor zowel bus als tram. Op DRIS-panelen op en rondom haltes worden de actuele aankomst- en vertrek informatie weergegeven. Voor het DRIS-systeem op de halte UCC is een viertal wijzigingen benodigd. Via deze VTW worden deze vier ontwerp wijzigingen in opdracht gegeven. Deze vier wijzigingen betreffen:</p> <ol style="list-style-type: none"> <li>1. Vier extra detectielussen voor de bus;</li> <li>2. Het verplaatsen van het grote DRIS-paneel (65") op de bushalte;</li> <li>3. Het verplaatsen van een drietal DRIS-panelen (42") op de bushalte;</li> <li>4. Het realiseren van een extra DRIS-paneel (42") op de bushalte;</li> <li>5. Het verplaatsen van het grote DRIS-paneel (55") op de tramhalte.</li> </ol> <p>Deze wijzigingen worden hieronder nader uitgewerkt in een viertal eisen.</p>

Betreft contracteis					
ID	Titel	Tekst	Type	ID	Fysiek object

Voorstel eistekst		
Voorstel eistekst	Datum ingediend	Eis
<p>1. Opdrachtnemer wordt gevraagd vier detectie-lussen met bijbehorende bufferloops te integreren in het ontwerp, te leveren en te installeren op de halte UCC. De feederkabel tussen de lus en de bufferloop dient beschermd te worden met een gewapende slang of mantelbuis.</p> <p>Voor de locaties van de detectie-lussen dient het voorstel in de email van [redacted] van 19-12-'17 14.27u aangehouden te worden. Voor de vierde lus, de uitmeldlus bij verlaten van het busstation, dient in overleg tussen Opdrachtnemer, Opdrachtgever, provincie Utrecht en mogelijk gemeente Utrecht een locatie/ oplossing bepaald te worden. Hiervoor neemt Opdrachtgever het initiatief.</p> <p>De specificaties voor deze lussen staan in het document Vecom Compact - installation guide (kenmerk: 9586_115_60100_VECOM-C_Installatie). Verder dient de Opdrachtnemer mantelbuizen aan te leggen van de afgaande bekabeling van de bufferloops naar de dichtsbijzijnde trekput. De mantelbuizen moeten dusdanig aangelegd worden zodat later op een eenvoudige wijze bekabeling in de mantelbuis kan worden aangebracht.</p>	2017-11-15	

<p>Toelichting: In het stationsgebied rondom halte UCC wordt het GPS-signaal verstoord door de aanwezigheid van de overkapping (OVT en Het Platform). Hierdoor kan het voorkomen dat actuele reisinformatie pas weer beschikbaar is wanneer de bus de ruimte onder overkapping verlaten heeft. Dit probleem is op te lossen door de aanleg van vier detectie-lussen. Twee voor aankomst en vertrek voor het oostelijk perron en twee voor aankomst en vertrek voor het westelijk perron.</p>		
<p>2. Opdrachtnemer wordt gevraagd een extra bevestiging voor een DRIS-paneel (inclusief voeding en mantelbuis voor de datakabel) te realiseren op de eerste bushalte (noordoost hoek) van de bushalte UCC. De voorgestelde locatie van deze DRIS is opgenomen in het document '171115 dris halte ucc optie 1'.</p> <p>Toelichting: Deze bushalte was in eerste instantie enkel voorzien als uitstaphalte, maar dit uitgangspunt is gewijzigd.</p>	2017-11-03	
<p>3. Opdrachtnemer wordt gevraagd de locatie van bevestiging van de drie DRIS-panelen op de bushalte UCC ter herzien zodat de DRIS-panelen in het midden van de bushalte kunnen worden gerealiseerd. De voorgestelde locatie van deze drie DRIS-panelen is opgenomen in het document '171115 dris halte ucc optie 1'.</p>	2017-11-03	
<p>4. Opdrachtnemer wordt gevraagd de locatie van het DRIS-informatiepaneel 65 inch (dat staat op de bushalte) te verplaatsen naar een locatie onderaan de vaste trap naar de bushalte. Het DRIS-informatiepaneel dient op 5,0m afstand van de vaste trap te staan. Zie bijlage '171219 positie overzichtspanelen'.</p>	2017-12-19	
<p>5. Opdrachtnemer wordt gevraagd de locatie van het DRIS-informatiepaneel 55 inch (dat staat op de tramhalte) te verplaatsen zodanig dat deze recht onderaan de roltrap naar de tramhalte staat. Zie bijlage '171219 positie overzichtspanelen'.</p>	2017-12-19	

#### Beschrijving wijziging

Via deze VTW wordt gevraagd om bovenstaande vijf ontwerp wijzigingen door te voeren in het UO. Uitvoeringswerkzaamheden zullen in een nadere/separate VTW worden overeengekomen.

POUHL heeft aanvullend de tekeningen verstrekt van de pendels waaraan de DRIS-en dienen te komen te hangen.

#### Gevolgen op ontwerp/realisatie/test

Discipline	Omschrijving	Paraaf	Datum
------------	--------------	--------	-------

#### Financieel

<b>Bedrag:</b>	De ontwerpkosten a.g.v. deze VTW zijn reeds overeengekomen in ON-VTW-140.2 "Opstellen UO rev C".
<b>Specificatie:</b>	n.v.t.
<b>Betaling</b>	n.v.t.
<b>Ingang per</b>	De ontwerpwerkzaamheden zijn meegenomen in het UO rev C o.b.v. ON-VTW-140.2.
<b>Overige voorwaarden</b>	De ontwerpwerkzaamheden zijn meegenomen in het UO rev C. De consequenties van de uitvoeringswerkzaamheden van deze VTW worden separaat overeengekomen in een aanvullende VTW. De consequenties van de gewijzigde planning worden overeengekomen in de HUP.
<b>Overige voorwaarden</b>	Mede door het ontbreken van informatie ziet BAM CUU geen mogelijkheden voor de realisatie van de vierde DRIS-lus, de uitmeldlus bij verlaten van het busstation. De vierde lus wordt verder opgepakt door POUHL en maakt daarmee geen onderdeel meer uit van deze VTW.

#### Toegevoegde documenten/bijlagen

Kenmerk	Titel	Revisiecode
	Positie overzichtspanelen	
9586 115 60100	9586_115_60100_VECOM-C_Installatie	1.41
171115	DRIS halte UCC	
<a href="#">1036-PER-TEK-2902 - 100 -0</a>	<a href="#">Steunen t.b.v. borden</a>	<a href="#">23-11-2015</a>
<a href="#">1701263-11</a>	<a href="#">Behuizing Utrecht busstation Dubbelzijde 42" TFT behuizing Perron Display</a>	<a href="#">05-12-2017</a>

Is akkoord door opdrachtnemer?		
Naam	Paraaf	Datum
BAM CUU Dhr. [redacted] Projectdirecteur	[redacted]	11-04-2018

Opdrachtgever		
Naam	Paraaf	Datum
M. Donders	[Signature]	26-4-2018

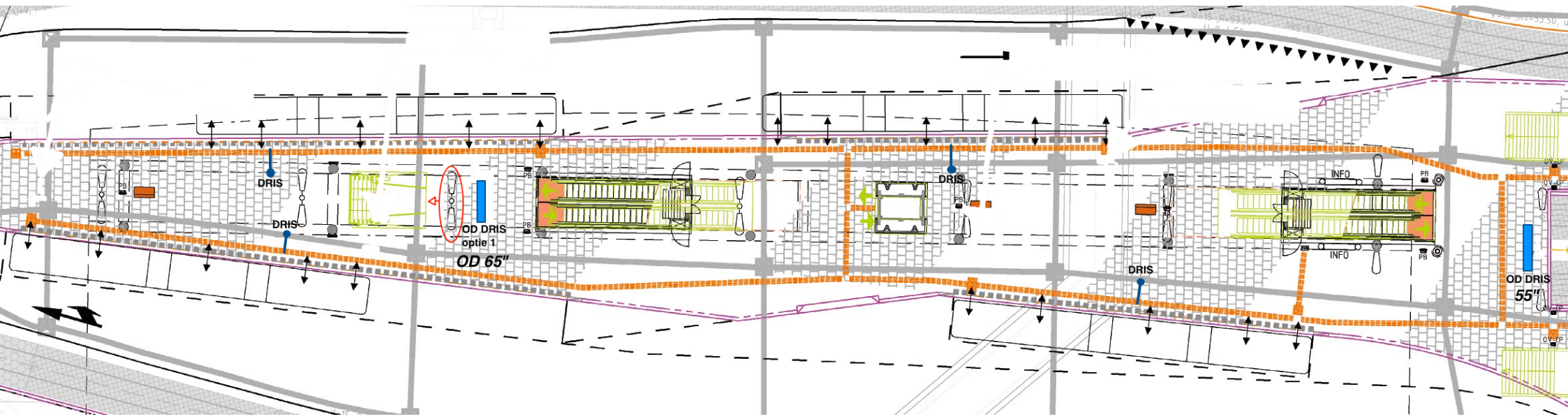



# VECOM Compact Installation guide



## About this Manual

© Copyright 2008 Peek Traffic B.V. Amersfoort, the Netherlands.

All rights reserved. No part of this document may be reproduced, in any form or by any means, without permission in writing from the publisher.

A publication of:

Peek Traffic B.V.  
Amersfoort, Nederland

Pub. No.: 9586 115 60100

Product : VECOM Compact

Title : VECOM Compact Installation Guide

Although this book has been written with greatest care, Peek Traffic B.V. disclaims all liability for the contents of this document other than described in "General terms and conditions of delivery of goods and services and Specific terms and conditions of delivery of systems and projects of Peek Traffic B.V. in Amersfoort, the Netherlands". These terms and conditions will be sent on request.

Should any errors or omissions be discovered or in case of improvement suggestions, please send relevant information to:

Peek Traffic B.V.  
Documentation and Training  
P.O. Box 2542  
3800 GB AMERSFOORT

or via e-mail to:

Documentatie.Training@peektraffic.nl

Version	Date	Author	Nature of Revision
1.0	28.05.06	Peek	Initial release
1.1	20.08.07	Peek	Editing and updating with latest VECOM-C(T) information
1.2	28.05.08	Peek	Revised version
1.3	27.05.09	Peek	Reformulated chapter 3: Interference Improved information on serial connections
1.4	25.08.11	TR/AJK	Added flat cable description to IO1609 wiring diagram
1.41	02.11.11	TR/AJK	Inserted missing pictures

## Table of contents

<b>1</b>	<b>Introduction .....</b>	<b>7</b>
	Purpose of this manual .....	7
	Conventions.....	8
	Relevant user documentation.....	8
<b>2</b>	<b>Loop installation considerations .....</b>	<b>9</b>
	Loop position for road traffic.....	9
	Loop position for rail traffic.....	11
<b>3</b>	<b>Interferences .....</b>	<b>15</b>
<b>4</b>	<b>Installation of loops .....</b>	<b>17</b>
	General .....	17
	Loop dimensions .....	17
	Cable groove preparations .....	18
	Cutting the cable groove.....	19
	Installation of the loop wire .....	21
	Testing.....	23
	Filling the groove .....	23
	Final test .....	23
<b>5</b>	<b>Installations of loop modules .....</b>	<b>25</b>
	Feeder cable.....	25
	Loop Module.....	26
<b>6</b>	<b>Installation of VECOM system.....</b>	<b>29</b>
	VECOM-C.....	30
	VECOM-CT.....	33
	Backplane.....	36
	Installation .....	37
	VECOM Control Module.....	42
	Interfaces.....	43
	VECOM Modulator Module (VMM).....	45
	VECOM Extension Module (VEM).....	49
<b>7</b>	<b>Intra-cabinet system connections .....</b>	<b>53</b>
	General .....	53
	Power supply (PSU) Power One .....	53
	Power supply (PSU) MGV.....	55
	SER I/O Module .....	56

Mounting rail .....	62
Loop Distribution Panel/Wide Style (LDP/WS) .....	63
Loop Distribution Panel-T (LDP-T) .....	66
I/O 1609/A Module .....	70
Interfaces .....	71
Power loop cable .....	75
<b>8 Synchronization of VECOM systems .....</b>	<b>77</b>
Synchronous interrogation .....	77
Exclusive interrogation .....	77
Connection .....	78
<b>9 Testing .....</b>	<b>79</b>
<b>10 Appendix A Loop length .....</b>	<b>81</b>
VECOM-VETAG communication .....	81
VECOM-VECOM communication .....	83
<b>11 Appendix B Connector pin arrangements .....</b>	<b>85</b>
Sub-D connectors .....	85
Combicon connector .....	85
Euro connector or Boxheader .....	86
<b>12 Abbreviations .....</b>	<b>87</b>



## Figures

Figure 1 Figure-of-eight loop .....	9
Figure 2 Loop position for two-way traffic.....	9
Figure 3 Loop position for three-lane traffic .....	10
Figure 4 Loop position for three-lane traffic .....	10
Figure 5 Figure-of-eight loop in case of interference from high voltage cables .....	11
Figure 6 Figure-of-eight loop between rails.....	12
Figure 7 Loop position between rails with transverse rods .....	12
Figure 8 Loop position for road and rail traffic .....	13
Figure 9 Loop position under both rails.....	13
Figure 10 Loop Dimensions.....	18
Figure 11 Indicating the position of the loop.....	18
Figure 12 Loop angles .....	19
Figure 13 Cutting of the groove .....	19
Figure 14 Groove cutting .....	20
Figure 15 drilling hole.....	20
Figure 16 The grooves are cut .....	21
Figure 17 Fixate loop wire in groove.....	21
Figure 18 Installing wire and protective tube .....	22
Figure 19 Connection between LDP/WS and Loop Buffer (LB).....	25
Figure 20 Connection between LDP-T and Loop Transceiver (LT).....	25
Figure 21 Loop module (LB) .....	26
Figure 22 Top and side view Loop Buffer (LB).....	28
Figure 23 VECOM-C rack .....	30
Figure 24 VECOM-C maximum configuration .....	31
Figure 25 VECOM-C connection diagram.....	32
Figure 26 VECOM-CT rack .....	33
Figure 27 VECOM-CT configuration .....	34
Figure 28 VECOM-CT connection diagram.....	35
Figure 29 Layout backplanes maximum configuration (Front view).....	36
Figure 30 Layout backplanes maximum configuration (Rear view).....	36
Figure 31 Connecting diagram VECOM backplane.....	38
Figure 32 Connecting diagram SER I/O backplane.....	39
Figure 33 Layout VECOM Control Module (VCM) .....	42
Figure 34 Connector positions VCM interface .....	43
Figure 35 VECOM Modulator Module (VMM).....	45
Figure 36 Connector positions VMM Interfaces.....	46
Figure 37 VECOM Extension Module (VEM) .....	49
Figure 38 Connector positions VEM Interfaces .....	49
Figure 39 Power Supply.....	53
Figure 40 Connection diagram Power supply (PSU) interfaces.....	54
Figure 41 SER I/O Module .....	57
Figure 42 Connector diagram SER I/O .....	57
Figure 43 Mounting rail .....	62
Figure 44 Loop distribution Panel/Wide Style (LDP/WS).....	63
Figure 45 LDP/WS schematic .....	63
Figure 46 Loop distribution cable and pinning .....	64
Figure 47 LDP/WS pinning .....	65
Figure 48 Loop distribution panel (LDP-T) .....	66
Figure 49 LDP-T Schematic.....	67
Figure 50 24V Power input .....	67
Figure 51 Layout flatcable .....	68
Figure 52 LDP-T pinning .....	69
Figure 53 Layout I/O 1609/A Module.....	70
Figure 54 I/O 1609/A Module .....	71
Figure 55 Power and powerloop of 24V .....	72

Figure 56 Cable from backpanel to I/O1609/A ..... 72  
 Figure 57 Cable between two I/O1609/A units ..... 72  
 Figure 58 Parallel input interface of I/O-1609/A ..... 73  
 Figure 59 Parallel output circuit of the I/O-1609/A..... 73  
 Figure 60 Layout power cable ..... 75  
 Figure 61 Connection between VECOM systems for synchronisation between two stations ..... 78  
 Figure 62 Connection between VECOM systems for synchronization between more than two stations ..... 78  
 Figure 63 Pin arrangement of 9 and 25 pin Sub-D connector (cable side view)..... 85  
 Figure 64 Three pin combicom connector..... 85  
 Figure 65 Pin arrangement of 10 96 pole euro/din-c/boxheader ..... 86

**Tables**

Table 1 Feeder cable length specifications ..... 26  
 Table 2 I/O Interfaces ..... 40  
 Table 3 RS485 Connections..... 41  
 Table 4 Primary power input and output ..... 41  
 Table 5 Secondary power input and output ..... 41  
 Table 6 Diagnostic interface connections ..... 43  
 Table 7 VCM I/O Interface connection table ..... 44  
 Table 8 Synchronization interface connection table..... 46  
 Table 9 VMM I/O Interface connection table ..... 47  
 Table 10 VMM Loop connection table..... 48  
 Table 11 VEM Synchronization interface connection table ..... 50  
 Table 12 VEM I/O Interface connection table ..... 51  
 Table 13 VEM Loop Interface connection table (X3)..... 52  
 Table 14 VEM Loop Interface connection table (X4)..... 52  
 Table 15 Power supply (Power One) unit connection table ..... 54  
 Table 16 Power supply (MGV) unit connection table ..... 56  
 Table 17 SER I/O Interface connection table ..... 58  
 Table 18 SER I/O RS232 Interface connection table ..... 59  
 Table 19 RS485 Bus termination..... 60  
 Table 20 RS485 Bus half duplex jumper configuration ..... 60  
 Table 21 RS485 Bus full duplex jumper configuration ..... 61  
 Table 22 RS232 Jumper Configuration ..... 61  
 Table 23 Loop distribution cable interface ..... 68  
 Table 24 Multi drop serial link (RS485) connection table ..... 72  
 Table 25 Parallel input I/O 1609/A connection table ..... 73  
 Table 26 Parallel output I/O 1609/A connection table ..... 74  
 Table 27 I/O 1609/A Address jumper settings ..... 75  
 Table 28 VETAG, max 1 simultaneous arrival ..... 81  
 Table 29 VETAG, max 2 simultaneous arrivals ..... 82  
 Table 30 VETAG, max 3 simultaneous arrivals ..... 82  
 Table 31 VETAG, max 4 simultaneous arrivals ..... 82  
 Table 32 VECOM only ..... 83  
 Table 33 VECOM only, 1 data messages per vehicle ..... 83

# 1 Introduction

This manual gives an overview of the installation and service aspects of the Peek VECOM-C(T) System. The correct and continuous functioning of the vehicle equipment is to a large degree dependent on the way in which it has been installed. This manual provides a number of specifications and regulations to help with the installation. For detailed information about the VECOM-C(T) system refer to the manual "system description" (see Related documentation).

## Purpose of this manual

This manual serves two purposes. On one hand it is to be used for installation of the VECOM system and on the other hand it is used as a reference for the purpose of service.

This manual contains the following chapters:

Chapter 1 <i>Introduction</i>	Contains an introduction and overview of the chapters in this document. This chapter contains further references of relevant user documentation and gives a survey of the used conventions used in this document.
Chapter 2 <i>Loop installation considerations</i>	This chapter describes the local installation consideration for the position of the loop in road-traffic and rail-traffic areas.
Chapter 3 <i>Interferences</i>	This chapter describes the local interference sources and the method to measure the location of the loops.
Chapter 4 <i>Installation of loops</i>	This chapter describes the assembly and interfaces of the loop.
Chapter 5 <i>Installations of loop modules</i>	This chapter describes the assembly and interfaces of the loop modules.
Chapter 6 <i>Installations of the VECOM system</i>	This chapter describes the assembly and interfaces of the VECOM system.
Chapter 7 <i>Intra-cabinet system connections</i>	This chapter describes the assembly parts which are optional and the interconnection cables for the VECOM systems.
Chapter 8 <i>Synchronization VECOM systems</i>	This chapter describes two methods for synchronization between VECOM and/or VETAG II VECOM systems.
Chapter 9 <i>Testing</i>	This chapter describes the test procedure for testing the system.
Appendix A <i>Installations of loop modules</i>	This chapter describes the length of the loop cables.
Appendix B <i>Installations of loop modules</i>	This chapter describes the pinning of the used connectors.
Index	This chapter contains the index of the interestedly subjects of this document.

## Conventions

This publication uses the following conventions to convey important instructions and information:

### Used symbols



**NOTE**

Notes contain helpful suggestions or references to materials not contained in this guide.



**CAUTION**

In this situation, you might do something that could result in equipment damage or loss of data.



**ESD**

Properly ground yourself in accordance with the guidelines before beginning any installation procedure. Electrostatic discharge can damage electronic components.









**WARNING**

You are in a situation that could cause injury or death. Before you work on any equipment, be aware of the hazards involved with electrical circuitry and be familiar with standard practices for preventing accidents.

## Relevant user documentation

The list below contains references (publications) to relevant user documentation:

	Publication number	Title
 1	9586 115 51101	System description
 2	9586 115 30113	VCU protocol
 3		On-line help WDMT
 4		
 5		
 6		
 7		

## 2 Loop installation considerations

### Loop position for road traffic

In the case of right-hand traffic, the transponder is mounted under the vehicle to the right (right from the middle of the vehicle). The figure-of-eight loop can then be installed eccentrically to the right of the traffic lane. Figure 1 shows some examples of a figure-of-eight loops and the installation directions of the loop wires. The arrows indicate the direction of winding in the figure-of-eight loops.

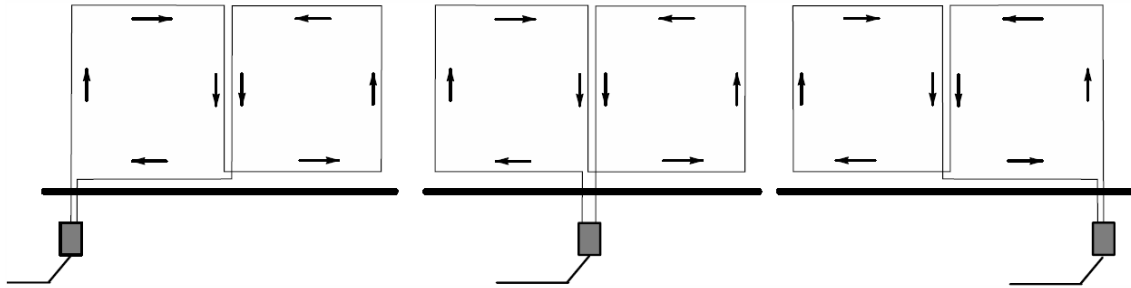

Figure 1 Figure-of-eight loop

In case the adjacent traffic lane is used for oncoming traffic the following procedure must be followed. The loop must then be separated at least 1 m from the separation line between the two lanes, see Figure 2. This will ensure that the loop is not activated by oncoming traffic.

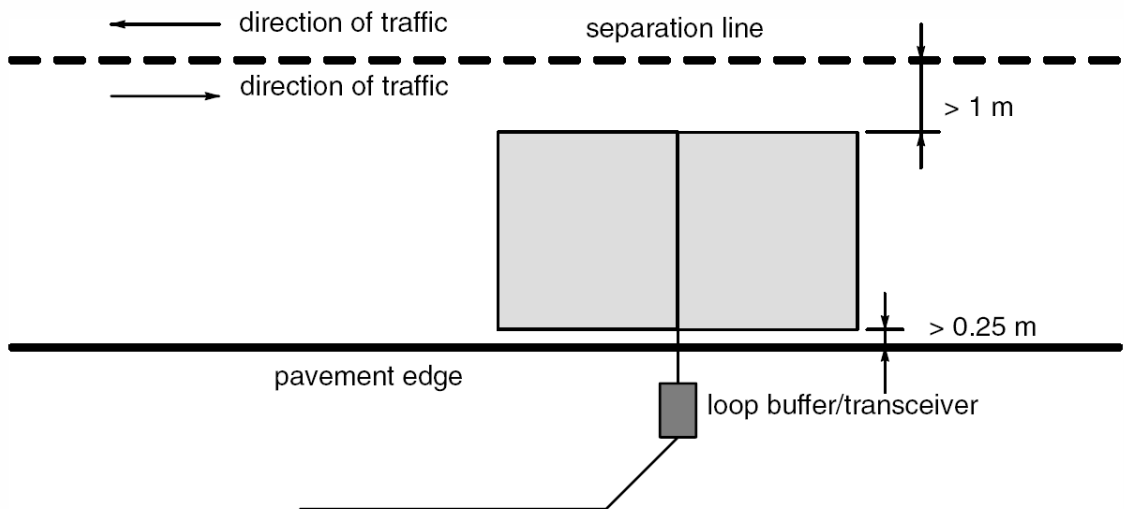

Figure 2 Loop position for two-way traffic

The loop must be separated at least 0.25 m from the pavement edge (for the purpose of cutting the loops), in the event that the loop is installed in the road (See Figure 2 Loop position for two-way traffic). In some cases, the loop may be installed under the pavement edge as described in paragraph "Loop position for rail traffic".

If the road accommodates multi-lane traffic, an area of the road surface can be covered with alternately overlapping loops, see Figure 3 and Figure 4. The loops must be projected so that there is no possibility that a transponder can travel over a space between the loops. A loop overlap of 0.3 m is recommended. For standardization, these loops are labelled A, B and C from left to right in driving direction.

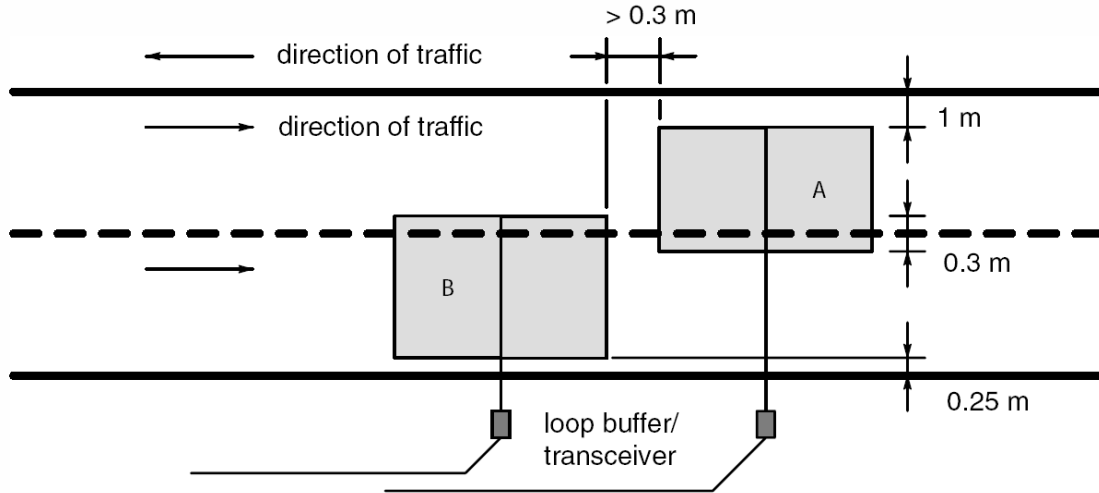

Figure 3 Loop position for three-lane traffic

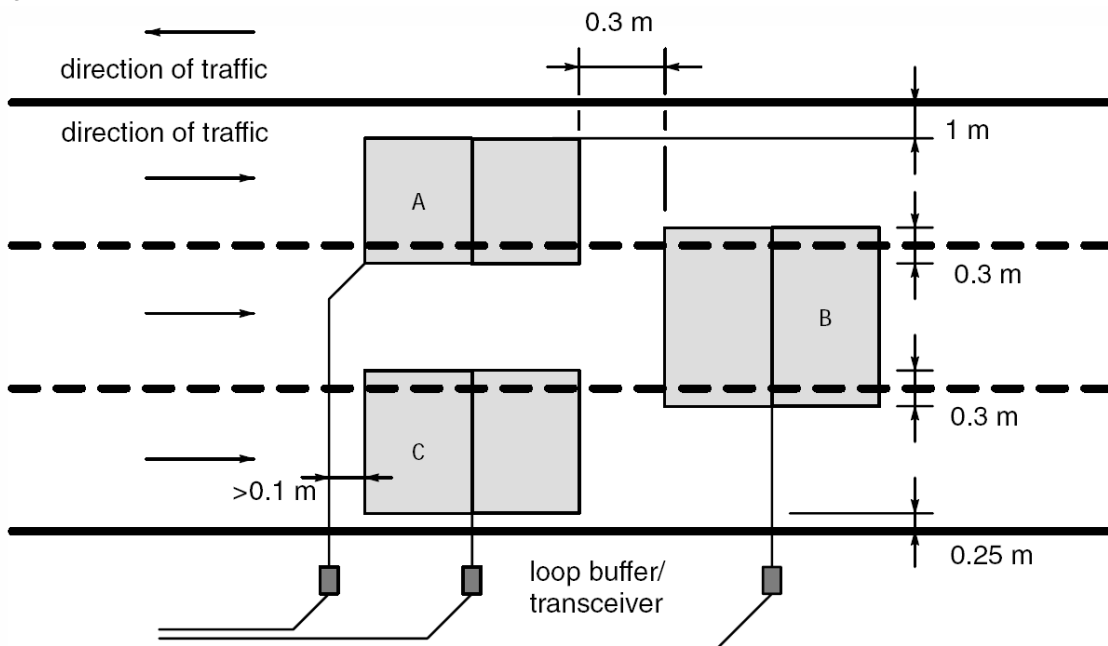

Figure 4 Loop position for three-lane traffic



**NOTE**

Do not place Loop Buffers/transceivers with the covers against each other to prevent crosstalk of interference signals through the passive part of the loops.

Loops must be separated at least 10 m from high voltage cables or other cables parallel to the loops which might cause an unpredictable interference field. If that is not feasible place the 8 shaped loop according Figure 5.

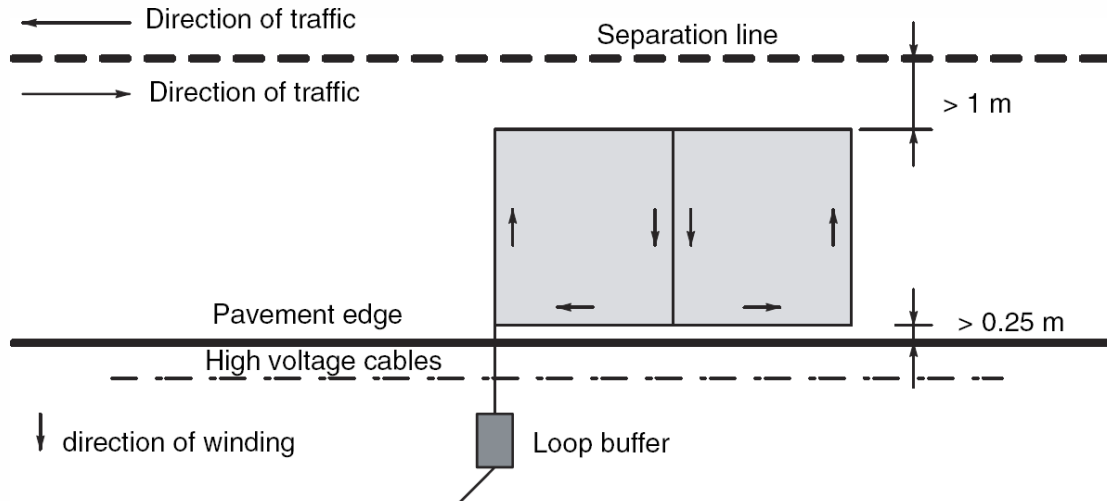

Figure 5 Figure-of-eight loop in case of interference from high voltage cables

The intersection or mid-point of this loop must be perpendicular to the interference field. The calculation of the loop length is given in chapter 4 paragraph "Loop dimensions section". This only applies when the mid-point of the loop is at right angles to the direction of traffic.

A minimum distance of 3 m should be maintained between the detection loop for vehicle detection and a loop in a different traffic lane. If these two types of loops are installed in the same traffic lane, a distance of 4 m must be maintained.

### Loop position for rail traffic

In general, in the case of rail vehicles, the transponder is installed in the centre, i.e. half way between the rails under the leading carriage. If only rail vehicles are to be detected, the loop may be installed between the rails. This implies that the separation between one side of the loop to the nearest rail must be greater than 0.1 m, and that the separation between this side and the rail is equally maintained over the entire length, both in the horizontal as well as the vertical plane, in order to ensure that the electromagnetic coupling is equal throughout the entire length of the loop, see Figure 6.

If a loop has to be installed in a bend in the tram rails, it is essential that the sides of the loop follow this bend and be installed parallel to the tram rails. Consequently, the loop must be installed as near as possible to the outer bend of the rails, to compensate for the swinging out of the transponder attached to the vehicle.

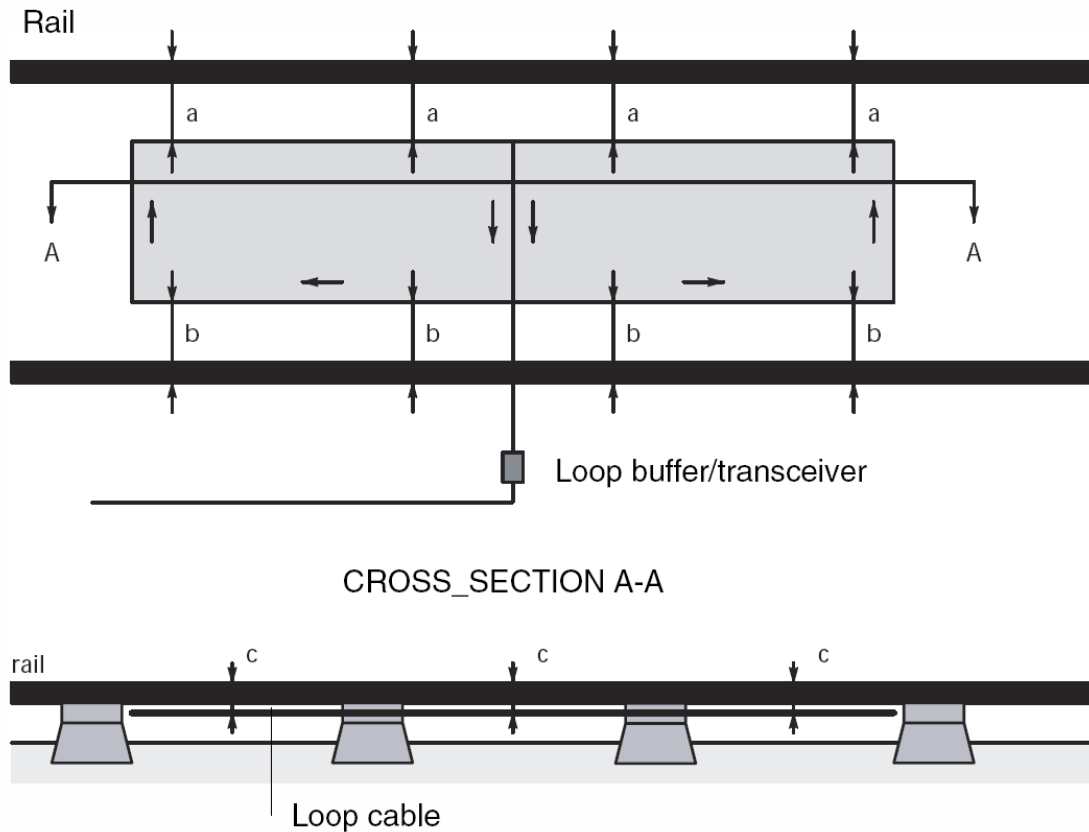

Tolerance on dimensions a, b, and c = + 0.02 m

Figure 6 Figure-of-eight loop between rails

The transverse rods near a loop must be electrically disconnected from the rail, see Figure 7.

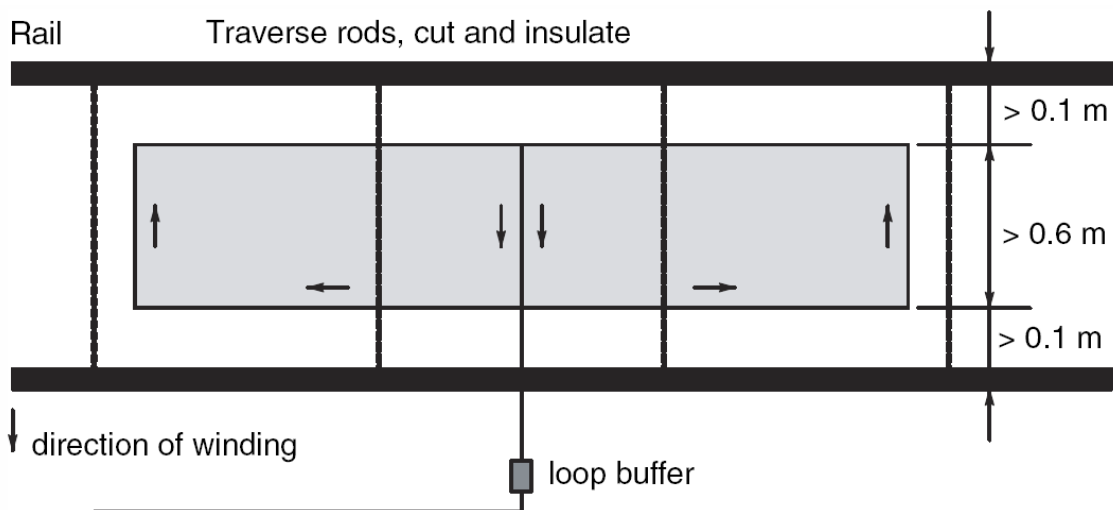

Figure 7 Loop position between rails with transverse rods

In the event that a loop is to detect both rail and road vehicles in the same traffic lane, the loop will have to be installed under one of the two rails. In such a case, the right-hand side of the loop must be separated at least 0.75 m from the rail, so that an adequate field may be created above the right-hand rail. It is advisable to install one side of the loop under the pavement, see Figure 8.



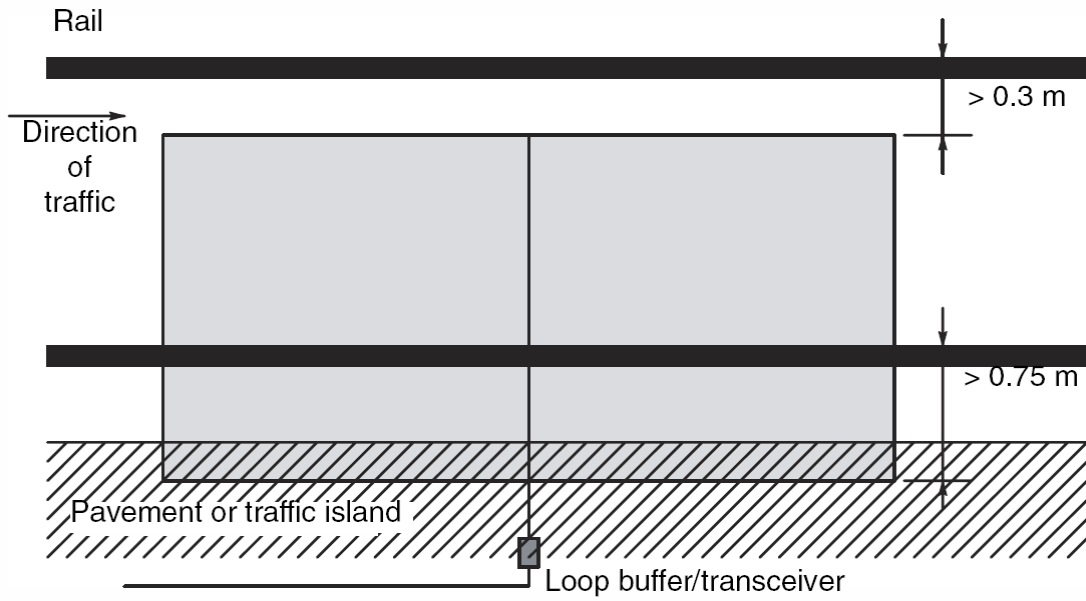

Figure 8 Loop position for road and rail traffic

It may also be necessary to install the loop under both rails. In that case, the side of the loop which is parallel to the rail, must have a minimum separation of 0.1 m from this rail, see Figure 9.

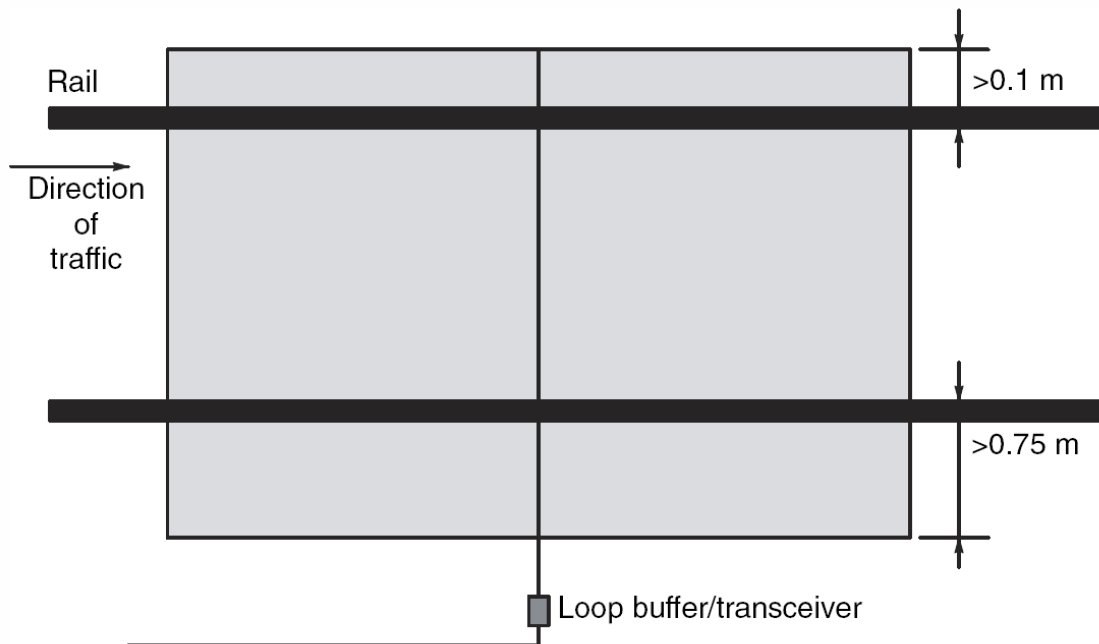

Figure 9 Loop position under both rails



### 3 Interferences

After the loops have been projected, the location for the installation of the loops, the Loop Buffers/transceivers and a path for the feeder cables must be finalized. To do this, a visit to the location must be made. A revision of the layout of the loops may be necessary because of metal objects or interferences at the planned position of a loop:

Metal parts attenuate the electromagnetic field of the VECOM loops and the VECOM transponders:

- (Unused) Rails;
- Associated metal plates;
- Drains;
- Manhole covers;
- Metal reinforcement in the road construction;
- Traverse rods, see chapter 2 paragraph "Loop position for rail traffic" and Figure 7.

Strong interference sources in the vicinity of the loop may disturb the communication between VECOM loops and vehicle transponders. Possible interference sources are:

- Power cabling in the neighbourhood of the loop
- Vehicle detection systems (trackcurrent circuits, detection loops)
- Vehicle traction currents in the tracks or the in motor cabling

If strong interferences are likely to be present, measurements must be made to investigate whether the VECOM communications will be disturbed.

If possible, the cause of any interference must be established and determined whether the degree of interference is acceptable. The maximum reduction of the influence of the interference field is achieved when the mid-point of the loop points to the direction of the interference source. However, the mid-point can not point in the driving direction because this makes it possible for a vehicle to drive over the loop with the transponder directly above the mid-point. In this case the transponder is not detected.

The distance between a communication loop and a detection loop should be as large as possible. Chapter 2: 'Loop installation considerations' gives an indication of the minimum distance.

After consultation with the local council or municipal engineers, the location of the loops can be finalized.



## 4 Installation of loops

### General

**NOTE**

Locally applicable norms and directions can determine the dimensions and shape of the loop configurations.

The communication between a vehicle set and a VECOM system consists of the exchange of identification codes. This will be the main consideration for determining the loop dimensions.

The exchange of identification codes can be followed by the transmission of data. E.g. loading and dumping vehicle data, such as timetable or trip-log data. It is recommended that a separate VECOM system is projected to cater for this eventuality.

Always install a figure-of-eight loop to reduce the present electromagnetic interferences. Causes of interferences are usually rail traffic and high voltage cables.

The loops must be located in such a way that the road or rail surface area is adequately covered by the loop(s) to cater for all possible vehicle movements.

### Loop dimensions

The distance between the two opposite sides of the loop which are closest to each other, must be between 1.0 and 3.0 m. When a loop is installed between rail tracks to detect rail vehicles, the minimum distance must be 0.6 m (a width of at least 0.8 m is preferred).

The passive component of the loop, up to the Loop Buffer, may not exceed 10 m in length. The circumference of the loop surface area may not exceed 16 m. Figure 10 shows the above mentioned dimensions schematically.

The Loop length seen in the direction of travel, defined in Appendix A, depends on:

- The required communication time;
- The scan time;
- The number of anticipated interrogations per loop;
- The number of simultaneously engaged loops;
- The maximum anticipated vehicle speed.

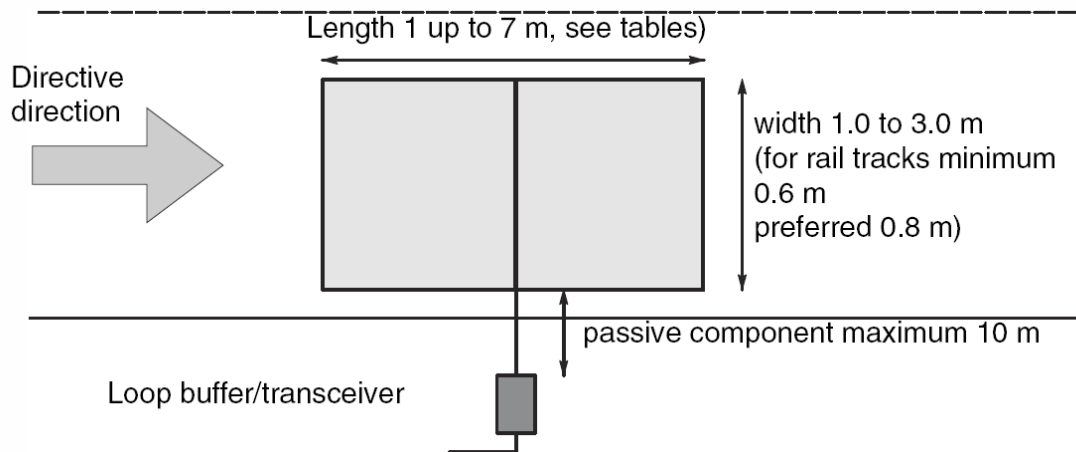

Figure 10 Loop Dimensions

**NOTE**

Keep the passive component of the loop as short as possible. Take the shortest route from loop to the roadside.

### Specification of loop wire

The loop wire must be flexible with a copper core of several conductors made of electrolytic copper. The insulation of the loop wire must consist of two layers. Insulation of the core is made of polyethylene (PE) or polytetrafluor-ethylene (PTFE, Teflon). The outer mantel may be of PE or PVC, and must be resistant to short periods of exposure to 180°C. The minimum core diameter must be 1.5 mm<sup>2</sup>. Recommended type of wire:

- VUV switchboard wire: 1 x 2.5 mm<sup>2</sup> (manufacturer: Draka).

### Cable groove preparations

The configuration, the dimensions and the route of the passive component of the loop, must be determined in advance (see chapter 2: 'Loop installation considerations').

Taking these specifications into consideration, the location of the groove in the road surface must be indicated with chalk or paint markings in a contrasting colour.



Figure 11 Indicating the position of the loop

## Cutting the cable groove

The groove must not contain bends of less than 135° and at each bend additional grooves must be incorporated at 15 cm from the bend.



Figure 12 Loop angles

The cable groove can be made in:

- Bitumen, asphalt-concrete and concrete;
- Clinker paving;
- Tram-rail bedding.

### Bitumen, asphalt-concrete and concrete

In the case of bitumen and asphalt-concrete road surfaces, the distance from the top layer of the road surface to the top of the loop wire must be at least 5 cm. The width of the groove must be 1 – 2 mm greater than the diameter of the loop wire. The groove for the passive component of various loops must have a mutual separation of at least 10 cm.



Figure 13 Cutting of the groove

When loops are installed in a road surface that is to be top dressed; the top of the road to the top of the loop wire; the depth of the groove must be:

- Bitumen and Asphalt between 1 to 3 cm;
- Concrete is at least 25 mm.



**NOTE**

The groove for the passive component of the loop must be wider because this part of the loop must be twisted. A wider groove can be made, for example, by using a double blade for cutting.



Figure 14 Groove cutting

Sharp edges and unevenness in the ground or on the sides of the groove must be removed, without damaging the upper edges of the groove. The groove must be rendered water and free from dust using an air compressor, which is equipped with a filter to remove oil and water particles from the air. In addition, the groove must be dried out with a gas burner, without damaging the upper edges of the groove.

On the side of the road surface where the passive component of the loop wire exists, a hole with a diameter equal to twice the diameter of the wire + 1.2 cm must be drilled, at an angle of 45° to the road surface, up to the verge. The distance between the side of the road surface and the hole, measured in the groove, must be minimally 20 cm and maximally 30 cm.

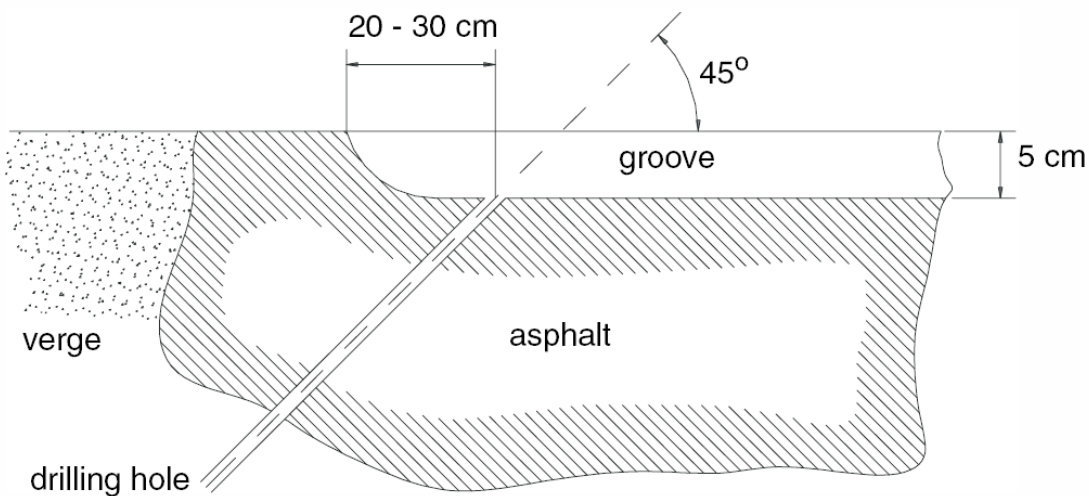

Figure 15 drilling hole

### Clinker paving

After the location of the loop on the clinker road surface has been determined, all the clinkers marked with chalk must be removed. Subsequently, a groove must be made in the underlying sand layer for laying the loop wire, to a depth of 2 cm ± 1 cm.



## Tram-rail bedding

If a groove has to be cut into the road for the loop, the depth of the transverse rods under the top of the road surface must first be determined, to avoid damage to them. If the bedding between the tram rails consists of shingle or a layer of stones, the loop wire must be installed above the bedding (see the next paragraph).



Figure 16 The grooves are cut

## Installation of the loop wire

The installation of the loop wire takes place in the following situations:

- 'Bitumen, asphalt-concrete, concrete' see page 17;
- 'Clinker paving' see page 18;
- 'Tram-rail bedding' see page 18.

### Bitumen, asphalt-concrete or concrete

The loop wire may only be installed in a completely dry groove. No loops may be installed if it is raining. The loop wire must be laid flat and tightly on the bottom of the groove. After installation, the loop wire must be fixed to the bottom, e.g. with the aid of wooden blocks or pieces of hosepipe at intervals of 30 cm.

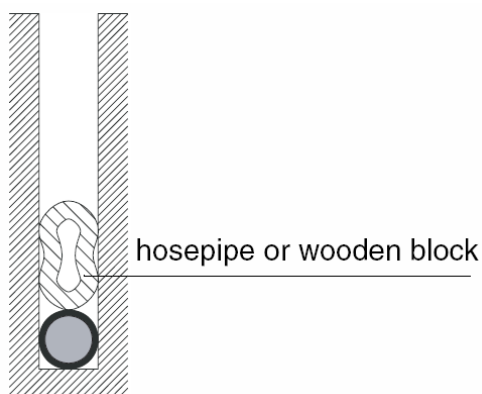

Figure 17 Fixate loop wire in groove

From the loop part to the side of the road surface, the two wires must be twisted and laid in the groove and fixed. Also from the groove to the Loop Buffer, the two wires are twisted. The loop wires must be twisted with a pitch of at least 8 twists per meter (10 to 15 twists per meter

is preferred) and protected with a fiberglass reinforced polyester tube. This tube runs through the hole drilled in the road surface to the groove in the road surface. The tube is sealed in the groove, so that epoxy resin can't enter it.

**NOTE**

The ends of the loop wire must be fitted with shrink caps if they are not connected immediately.

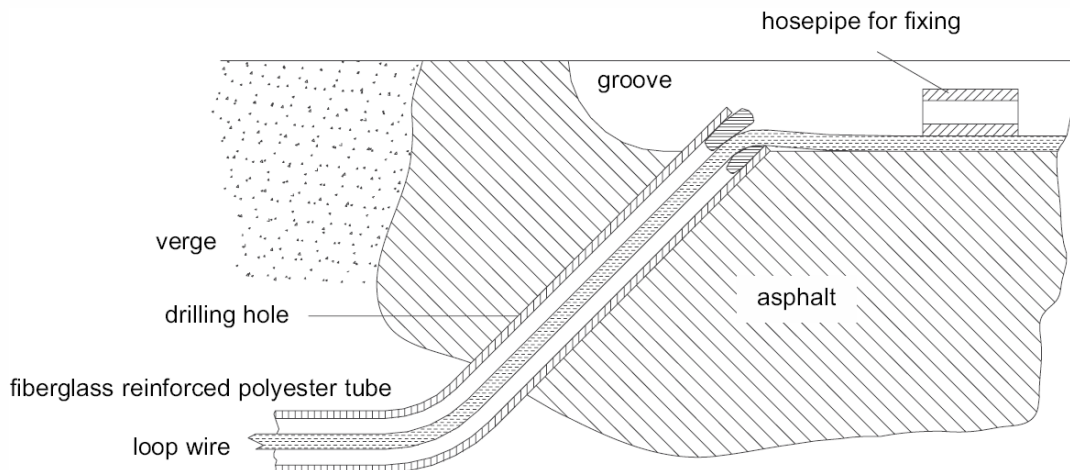

Figure 18 Installing wire and protective tube

**Clinker paving**

Lay the loop wire into the groove and fix it with aid of synthetic pins or tubes at the corner of the loop.

**NOTE**

You can put the loop wire in a frame of tubes to make it recognizable as a loop configuration for road construction workers.

**NOTE**

The ends of the loop wire must be fitted with shrink caps if they are not connected immediately.

**Tram-rail bedding**

If the bedding between the tram rails consists of shingle or a layer of stones, the loop wire must be installed above the bedding. In that case, the loop wire must be protected with fibreglass reinforced, crush-proof synthetic tubes in the stipulated frame configuration. The tubular frame must be fixed to the transverse rods between the rails. The passive component of the loop wire must be twisted with a pitch of 8 twists per meter (10 to 15 twists per meter is preferred) from the loop to the Loop Buffer and protected with fibreglass reinforced polyester tube. In order to prevent movement of the loop wire in the tubular frame, the tubes must be filled with synthetic foam.

**NOTE**

The ends of the loop wire must be fitted with shrink caps if they are not connected immediately.

## Testing

After the loop has been installed, and before the groove is filled, the following measurements must be made. The loop wire must not be connected to the Loop Buffer:

- Conductivity of the loop wire  
The conductivity of the loop wire is tested with a continuity test or by resistance measurement.
- The insulation resistance to earth  
The insulation resistance to earth must be measured with 500 V DC with respect to a probe which must be inserted vertically into the ground to a depth of at least 0.5 m. The insulation resistance must be greater than 200 MΩ.

## Filling the groove

After the loop is installed in the groove and tested (see the previous paragraph 'Testing'), the groove is filled with:

- sand and clickers for clinker paving must be restored  
The groove must subsequently be closed. During this process, the loop wire must be held down on the bottom of the groove. The deviation of the positioning of the loop with respect to the specified configuration may be up to 1 cm.
- pressurized bitumen R85/25 for bitumen, asphalt-concrete and concrete  
After allowing sufficient time for it to set, the surplus bitumen is evened out so that the groove is filled completely. After the surplus has been removed, a flame is applied to the top layer of the groove in order to make this surface level with the existing road surface.

If parts of the groove are not adequately filled, more heat must be applied, until the bitumen is again liquified, and the groove is to be topped up as necessary.

## Final test

After the groove of the loop has been filled and after the epoxy resin has hardened, the conductivity and insulation measurements outlined in the paragraph 'Testing' must be repeated.



## 5 Installations of loop modules

### Feeder cable

Unlike vehicle detection loops, the communication loop always consists of a single winding, which is not coupled permanently via a sealed sleeve to a feeder cable, but via a Loop Buffer/transceiver.

### Supply voltage

A feeder cable consists of four conductors which are enclosed in a metallic mantel and screen. Two of the conductors are implemented on the one hand for the communications signals (balanced) and on the other, for the supply voltage of +24V (VP24) to the loop module, while the other two conductors are implemented for the common return (V00), see Figure 19 for Loop Buffer and Figure 20 for Loop Transceiver.

The feeder cable shield is connected to the cabinet earth.

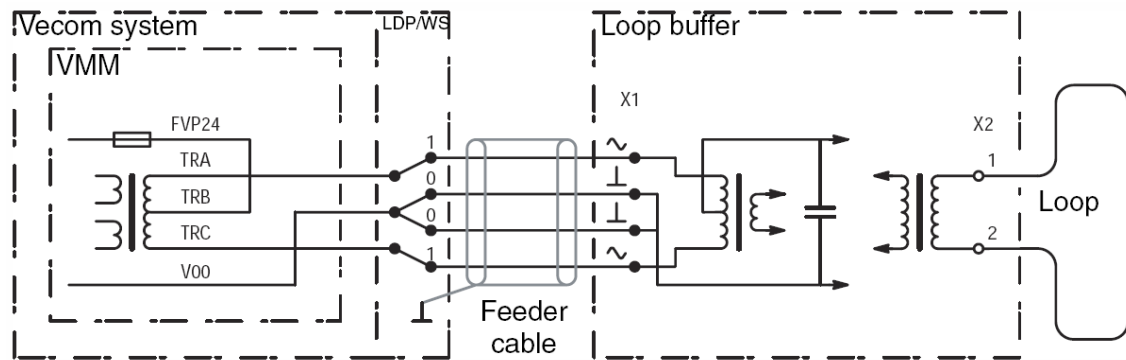

Figure 19 Connection between LDP/WS and Loop Buffer (LB)

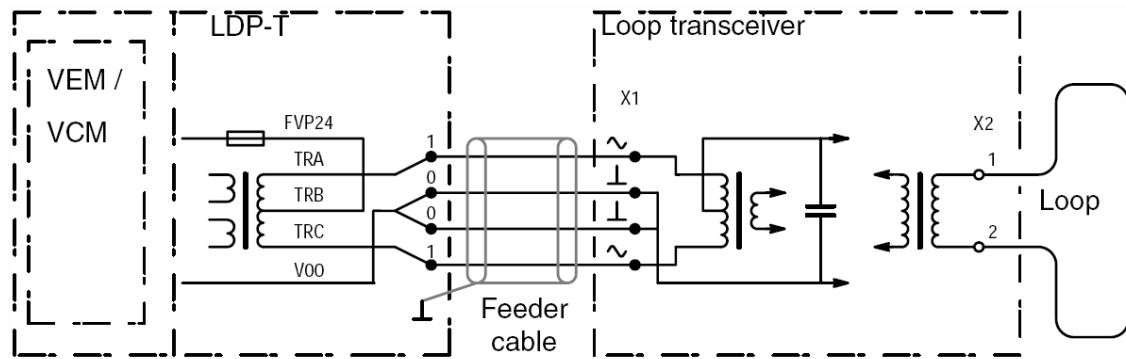

Figure 20 Connection between LDP-T and Loop Transceiver (LT)

The loop module must be buried close by the loop configuration in the verge or in the pavement, considering that the passive component of the loop, including 0.5 m additional length at the loop module, must not be longer than 10 m.

### Specifications

Each loop module is connected by a separate cable to the VECOM system. The feeder cable should consist of ground cable with a braiding inside the outer mantel and four conductors with a minimum cross section of 1.3 mm<sup>2</sup>. The default feeder cable type is VO-YMvKas 4 x 1.5 mm<sup>2</sup>.

The maximum permissible length is defined in the table below.

Cable specifications	Standard length		Optional length	
	VECOM-C	VECOM-CT	VECOM-C	VECOM-CT
Max. length	300 m	600 m	600 m	1000 m
special conditions	-		Feeder cable 4 x 2.5 mm <sup>2</sup> Max Loop circumference = 13m Noise immunity is reduced	

Table 1 Feeder cable length specifications

It is allowed to connect several loop modules with the same cable to one single VECOM system (never to different unsynchronized VECOM systems), it is then recommended to implement the following type of cable:

- Twenkacom instrumentation cable PPOV-2AF 4 x 2 x 1.3 mm<sup>2</sup> (manufacturer: TKF).

Before connecting the feeder cable test it's connectivity and it's isolation as described on page 21 "Testing".

Testing must also be carried out with this cable. The insulation between the conductors must be tested mutually, as well as between the braiding with respect to ground (probe or safety electrode).

## Loop Module

The module types are:

- Loop Buffer (LB);
- Loop Transceiver (LT).



Figure 21 Loop module (LB)

**NOTE**

The Loop Buffer (LB) is used in VECOM-C and the Loop Transceiver (LT) in VECOM-CT configuration.

A loop module is a transmit-receive amplifier. The purpose of the loop module is to provide a galvanic separation between the loop with its feeder cable and the VECOM system. The loop module enclosure is factory filled with resin so that the amplifiers are hermetically sealed. Only the connector blocks are accessible, see Figure 22.

**NOTE**

The VECOM system must always be switched off, when work is being carried out on the loop module, feeder cable and loop.

**Installation**

Proceed the following steps to install the Loop module (LB/LF) as follows:

1. Connect the cables after testing (see paragraph 'Testing'). The loop wire and feeder cable can be fed into the loop module via watertight glands (see the next paragraph "interface connections").
2. Finish the cable ends with waterproof mastic tape, type 01-7040.
3. Place the loop module horizontally on the bottom of the trench, which is at least 0.15 m depth in respect to the road surface.
4. After connection of the cables you must:  
Perform functional checks (see chapter 9: 'Testing'.);  
Ensure that the cable glands are waterproof.
5. Seal the loop module with epoxy resin:  
Recommended: Loop Buffer resin 2217 (amino-epoxy resin, manufacturer: Filoform B.V., Utrecht);  
Substitute: Scotchcast 2140U (manufacturer 3M).

The Loop Buffer resin must be thoroughly mixed for 2 minutes before it is poured and it should be of a homogeneous color. It should be mixed at a temperature above 10°C. It may be poured at an outdoor temperature above 0°C.

The Loop Buffer resin can be injected into the Loop Buffer either in the conventional way or with the aid of a grease gun with ball bearings. The implementation of a gun without ball bearings is not advisable, because in that case there is insufficient pressure. The Loop Buffers/ transceivers must be injected with resin in the enclosure in the region of the terminal blocks until the whole enclosure is filled.

Wait for approximately 15 minutes to enable air bubbles to escape (at the connector positions). When the resin becomes sticky the Loop Buffer may be closed with the lid provided.

6. The loop module must be buried to a depth of about 0.3 m under the grass verge. The loop module must be covered over with a concrete tile.

**NOTE**

Do not place loop module with the covers against each other to prevent crosstalk of interference signals through the passive part of the loops.

Keep a distance of at least 10 cm between the passive parts of two loops.

7. The cable outlet groove may be filled within half an hour after the Loop Buffer resin has been injected. Wait at least another half an hour because of the resin hardening process.

## Interfaces

### Loop wire

The loop wire must be twisted in the loop module and connected with the implementation of cable end pins or pinched cable connectors to a two-way terminal block X2.

### Feeder cable

The feeder cable is connected to a four-way terminal block X1. The conductors for the communication (TRA and TRC) are connected on terminals indicated with  $\sim$ . The other two conductors (or the screening of the cable in case of a two wire cable) are fitted with cable end pins and connected to the terminals indicated with ' $\perp$ '. The two terminals which are indicated with ' $\perp$ ' are mutually connected. The return of a two or three wire cable is to be connected to one of these points only.

The Loop Transceiver has an extra terminal indicated with ' $\perp$ ' to connect the screen of the cable in case of a 4 wire cable with screen (preferred).

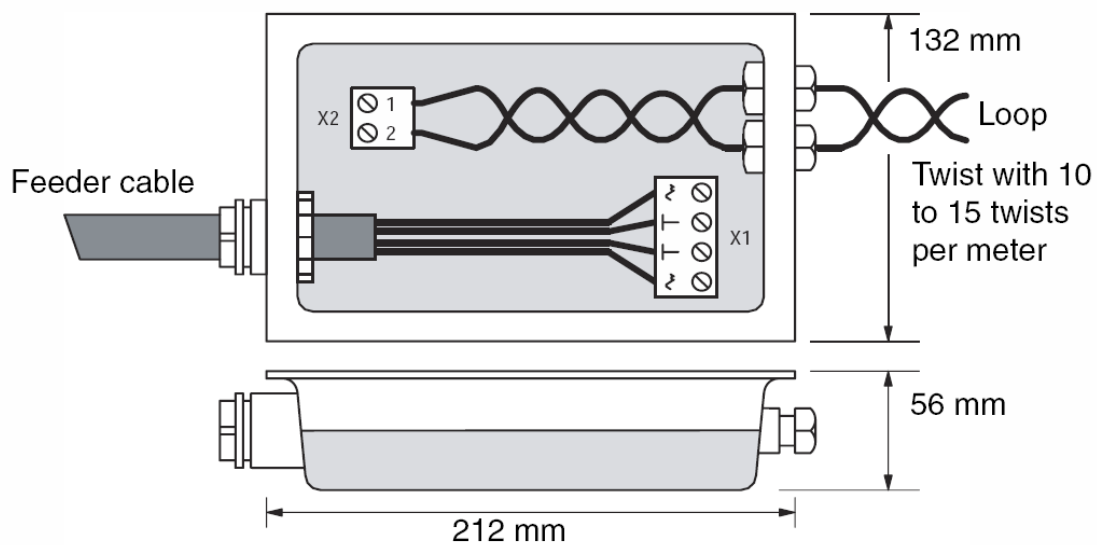

Figure 22 Top and side view Loop Buffer (LB)

The loop transceiver has an extra GND ' $\perp$ ' terminal where the cable screen may be connected. Preferably the screen is NOT connected at the Loop Transceiver side. (This improves the immunity against inductive coupled noise but decreases immunity against capacitive coupled noise).



## 6 Installation of VECOM system

The following chapter describes the core hardware components of the VECOM system. The following data is given for each component:

- Lay-out of the unit with connectors, jumper positions and the meaning of the LED's;
- Explanation of the jumper positions;
- Tables with the connector pins;
- Specifications of all relevant input and output signals.

The VECOM compact configurations can be mounted in various rack types of 3HE. The width of the rack will be defined by the number of configurations, the basic configurations are:

- 'VECOM-C' see page 30;
- 'VECOM-CT' see page 33.



### NOTE

The Backplane, the PCB guides and the optional power connector must be installed with the routed cables before the rack is mounted into the cabinet. The modules of the VECOM system must be installed by sliding the printed circuit board of the module over the guiding from the front to the rear of the rack. At the rear these modules will be connected to the Backplane connectors. The PSU has its own power connector at the rear. All modules will be secured by a screw at the front of the module.

## VECOM-C

The configuration of VECOM-C consist of the following hardware components:

Rack with backplane and:

- ' Power supply' width: 8TE;
- 'VECOM Control Module (VCM)' width: 6TE;
- 'VECOM Modulator Module (VMM)' width: 6TE ;
- Optional 1...2 'SER I/O Module' width: 6TE.

Rail mount modules:

- 'Loop Distribution Panel/Wide Style (LDP/WS)' ;
- Optional 1...2 'I/O 1609/A Module'.

Module near the loops:

- 1...8 Loop Buffer (LB), see 'Loop Module' .



Figure 23 VECOM-C rack

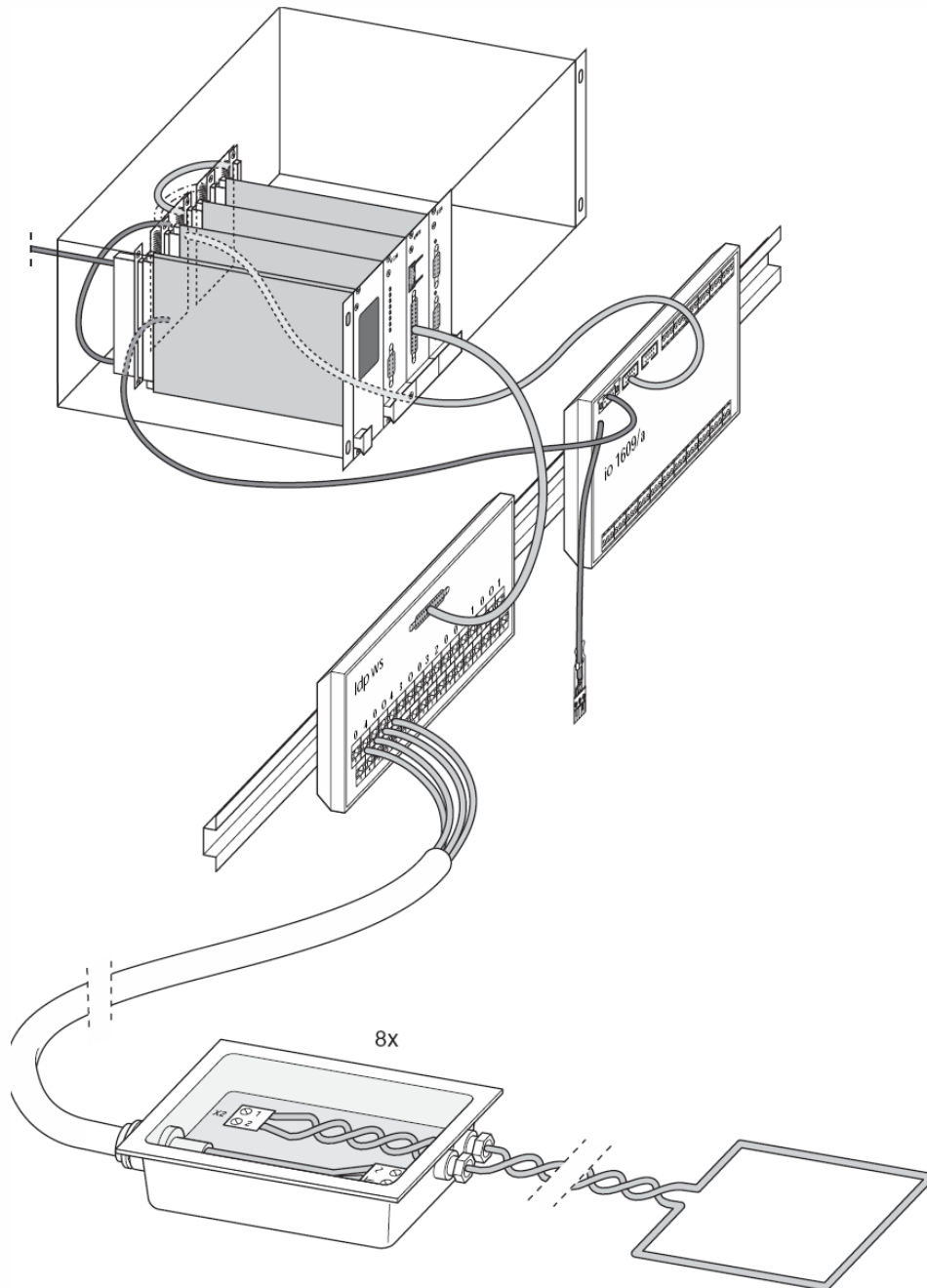

Figure 24 VECOM-C maximum configuration

The maximum configuration of a VECOM-C system is shown in Figure 24.

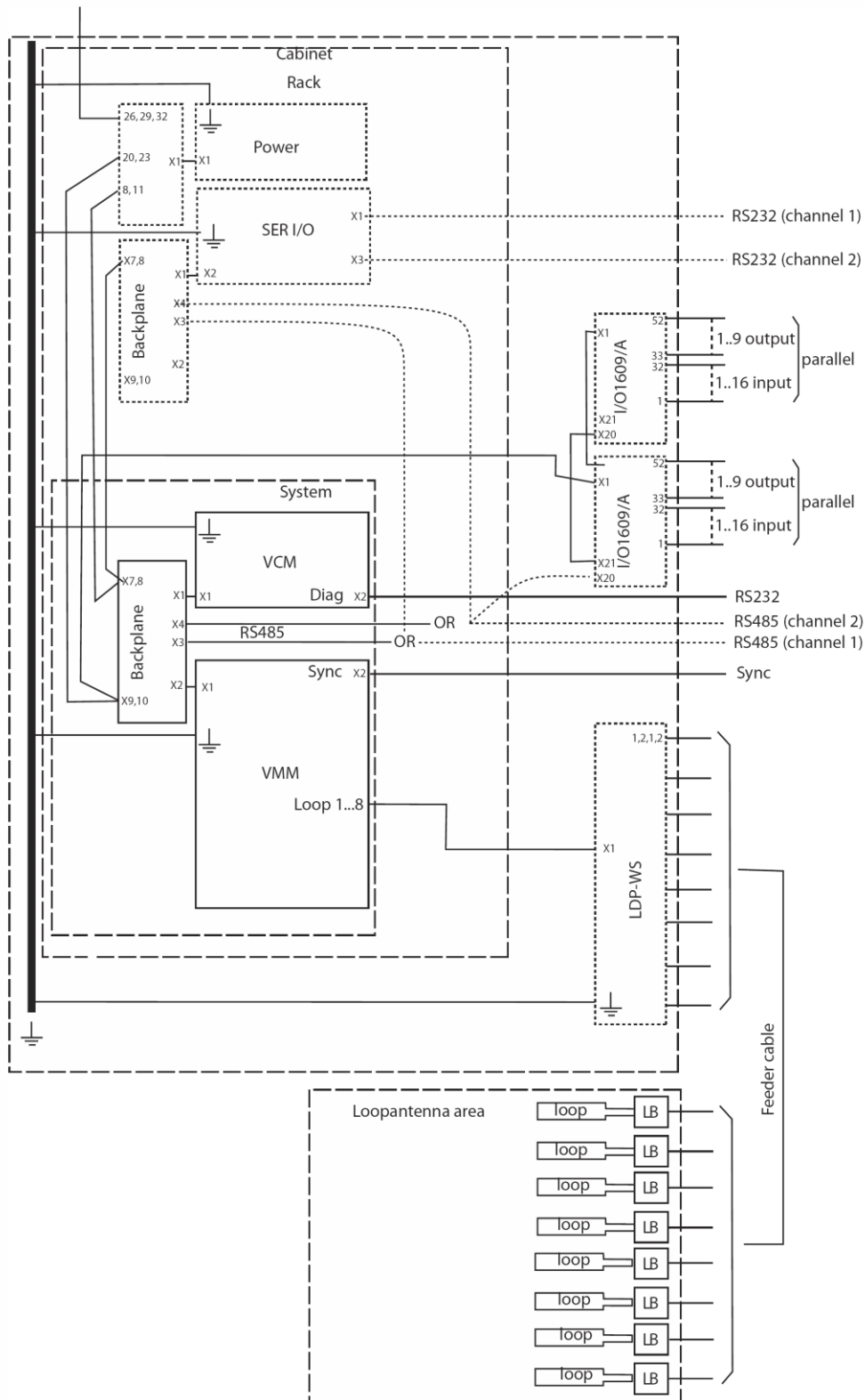

Figure 25 VECOM-C connection diagram

## VECOM-CT

The configuration of the VECOM-CT consist of the following hardware components:

Rack with backplane and:

- 'Power supply' width: 8TE;
- 'VECOM Control Module (VCM)' width: 6TE;
- 'VECOM Extension Module (VEM)' width: 6TE;
- Optional 1...2 'SER I/O Module' width: 6TE.

Rail mount modules:

- 1...2 Loop Distribution Panel-T (LDP-T) ;
- Optional 1...2 'I/O 1609/A Module'.

Module near the loops:

- 1...8 Loop Transceiver (LT), see 'Loop Module'.



Figure 26 VECOM-CT rack

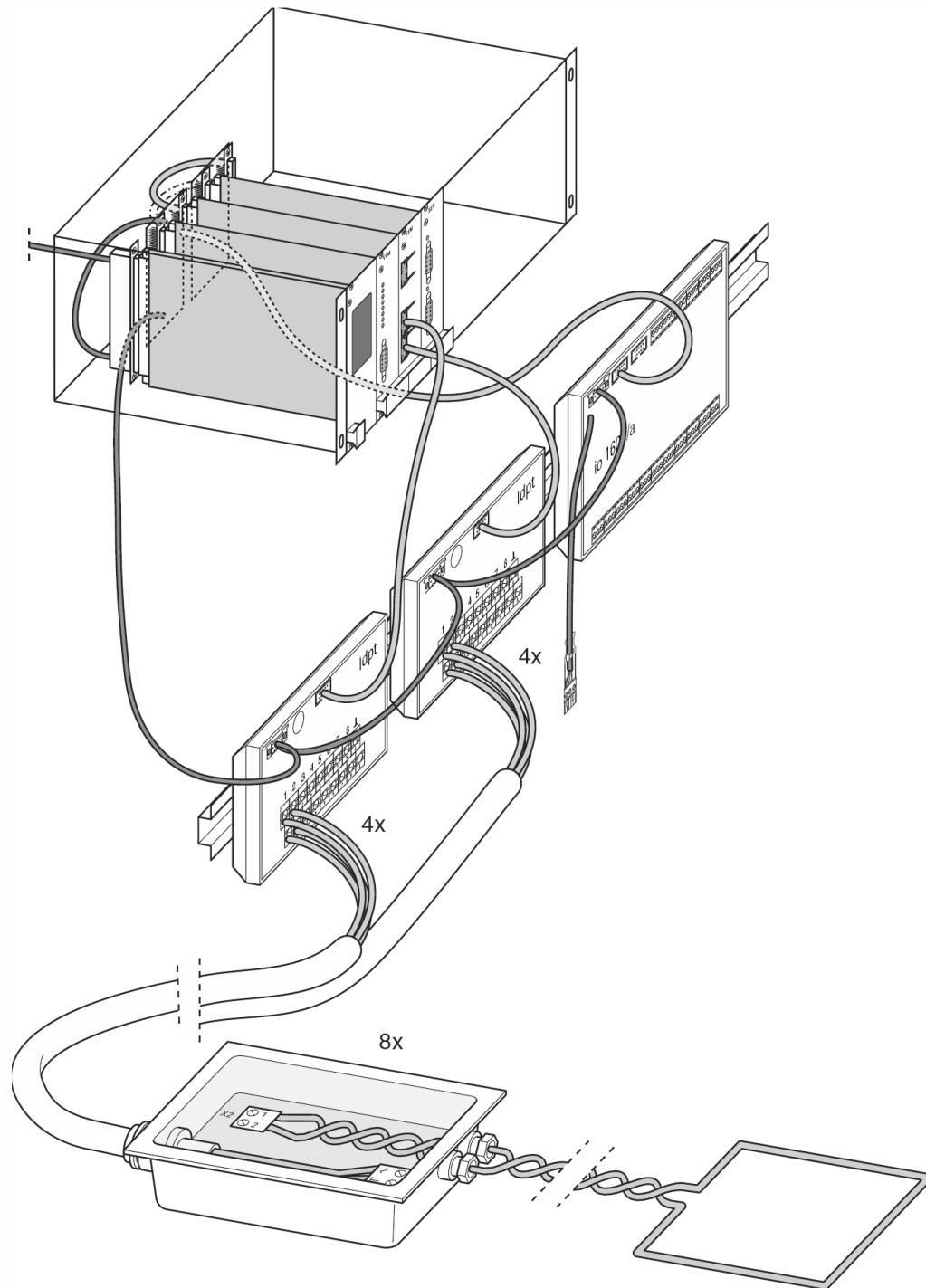

Figure 27 VECOM-CT configuration

The configuration of a VECOM-CT system is shown in Figure 27.

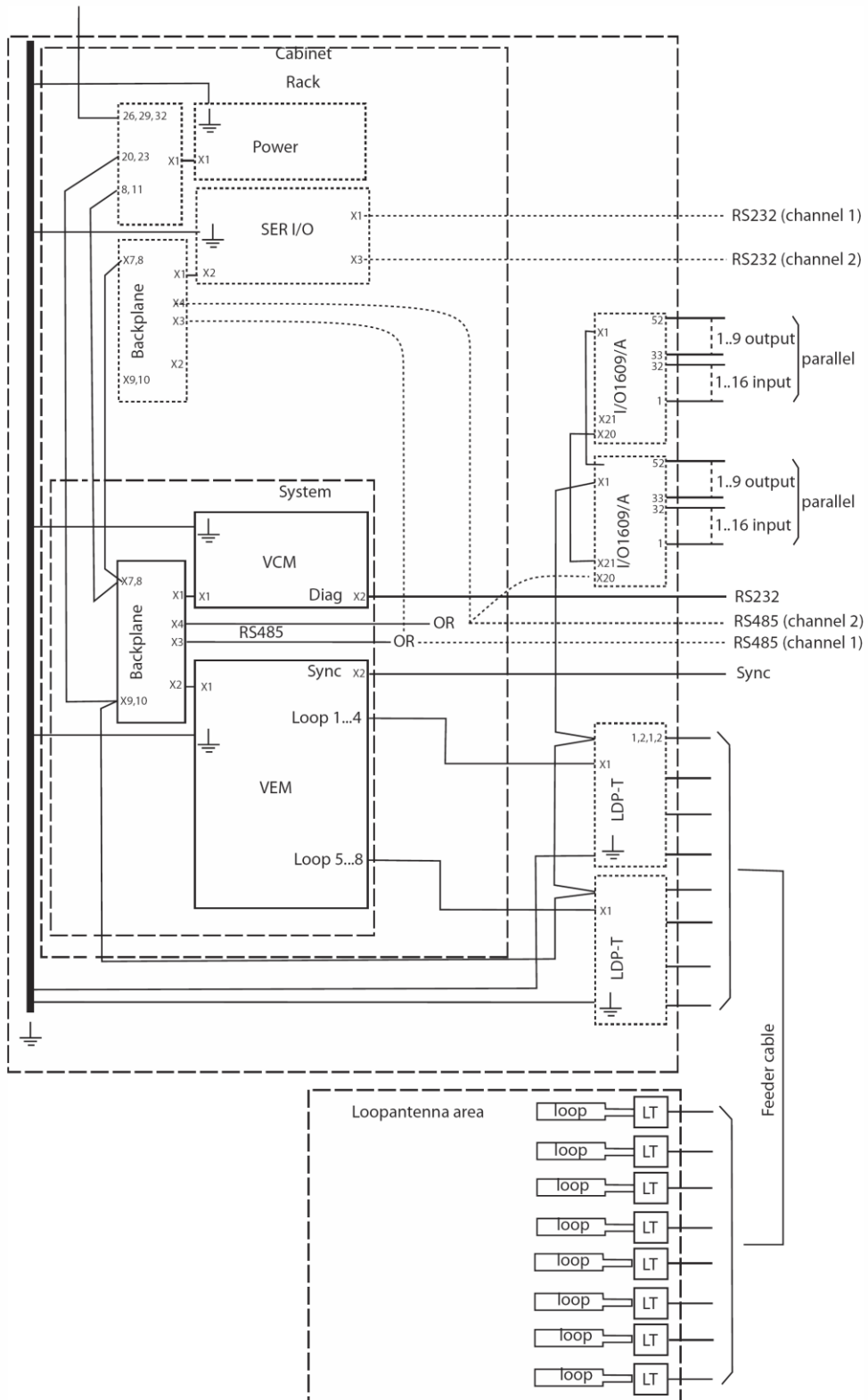

Figure 28 VECOM-CT connection diagram

## Backplane

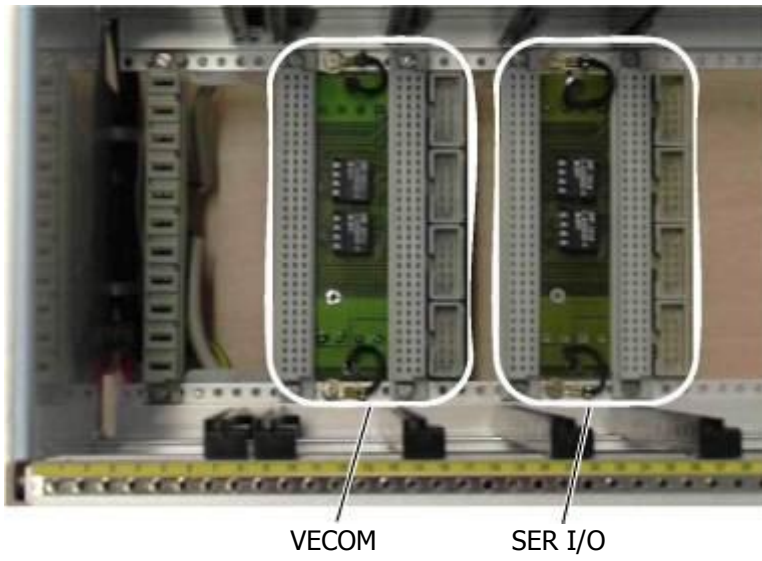

Figure 29 Layout backplanes maximum configuration (Front view)

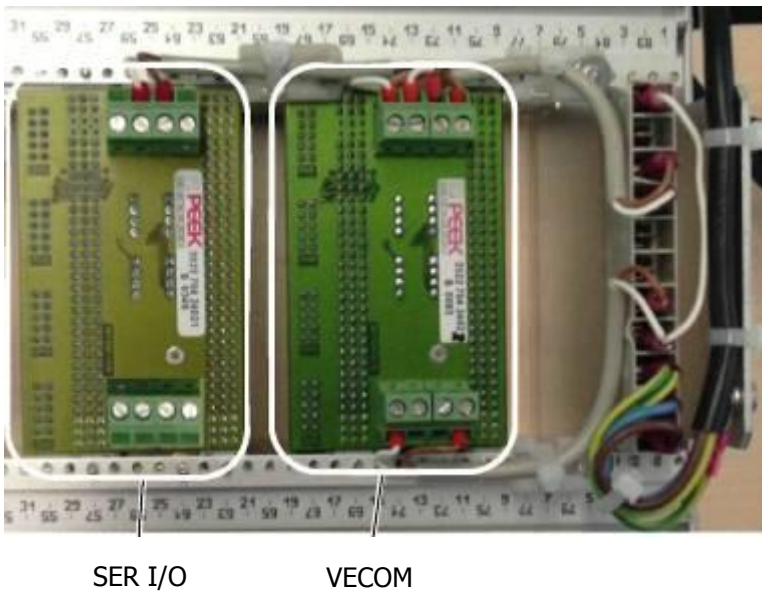

Figure 30 Layout backplanes maximum configuration (Rear view)



## Installation

### VECOM Backplane

1. Install the backplane with the bolts at the correct position according the configuration plan (see Figure 30).
2. Install the PCB guide in front of the two DIN-C connectors of the backplane in the rack.
3. Connect the following interfaces:
  - Ground;
  - Primary Power Input /Output;
  - I/O interfaces (DIN-C) VCM, VMM or VEM, SER I/O;
  - RS485 interfaces to the I/O 1609/A Module and/or the SER I/O backplane;
  - Secondary Power Input/output, if needed.

### SER I/O Backplane

1. Install the backplane with the bolts at the correct position according the configuration plan (see Figure 30);
2. Install the PCB guide in front of the two DIN-C connectors of the backplane in the rack;
3. Connect the following interfaces:
  - Ground;
  - Loop the Primary Power Input /Output from the VECOM backplane
  - I/O interfaces (DIN-C) SER I/O;
  - Loop the RS485 interfaces from the VECOM backplane;
4. If applicable, use the optional cable clamp at the rear of the backplane to route the RS485 interfaces properly.

### VECOM Interfaces

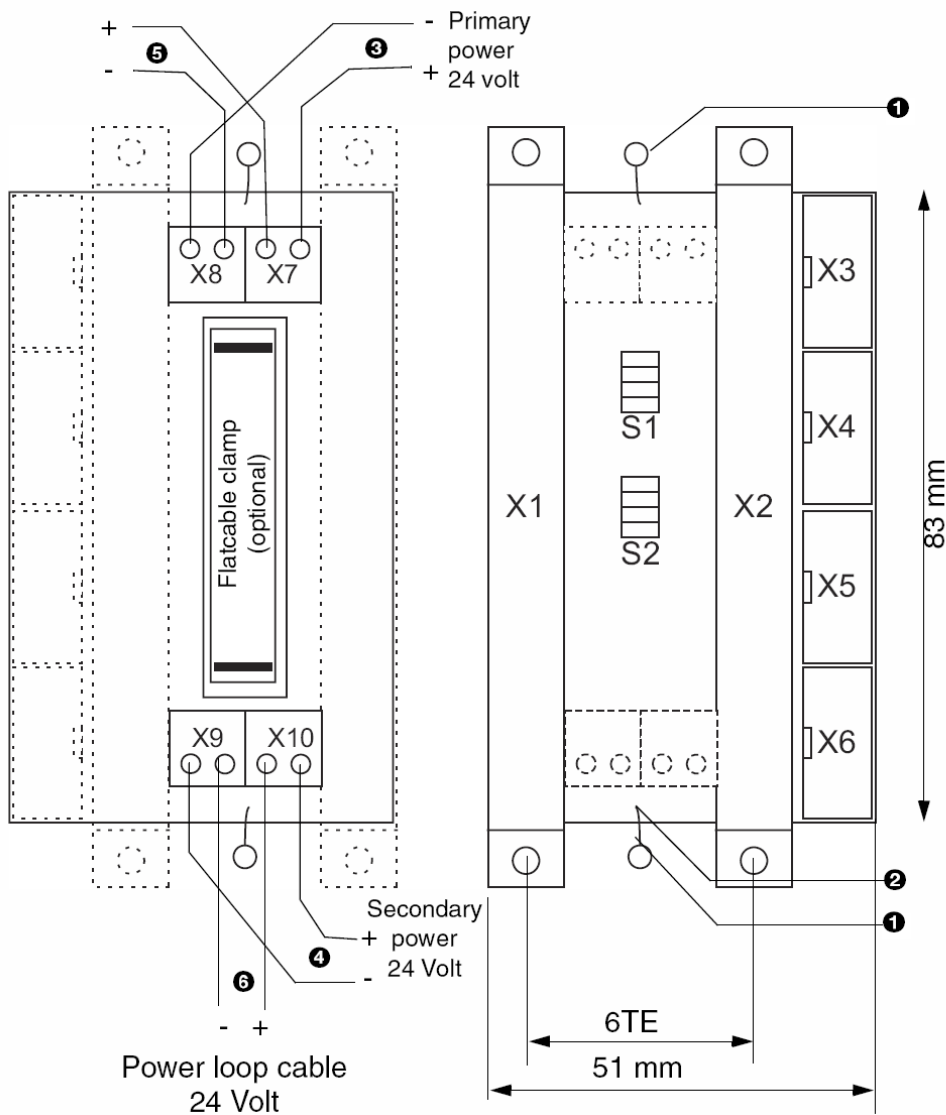

Figure 31 Connecting diagram VECOM backplane

- Ground (**1**, **2**);
- I/O interfaces (X1, X2);
- RS485 interfaces (X3, X4);
- Primary Power Input /Output (X7, X8) (**3**);
- SER I/O Primary Power Input /Output (X7, X8) (**5**) (if applicable);
- Secondary Power Input/output (X9, X10) (**4**);
- Secondary Power Input/output (X9, X10) (**6**), for LDP-T and I/O 1609/A.

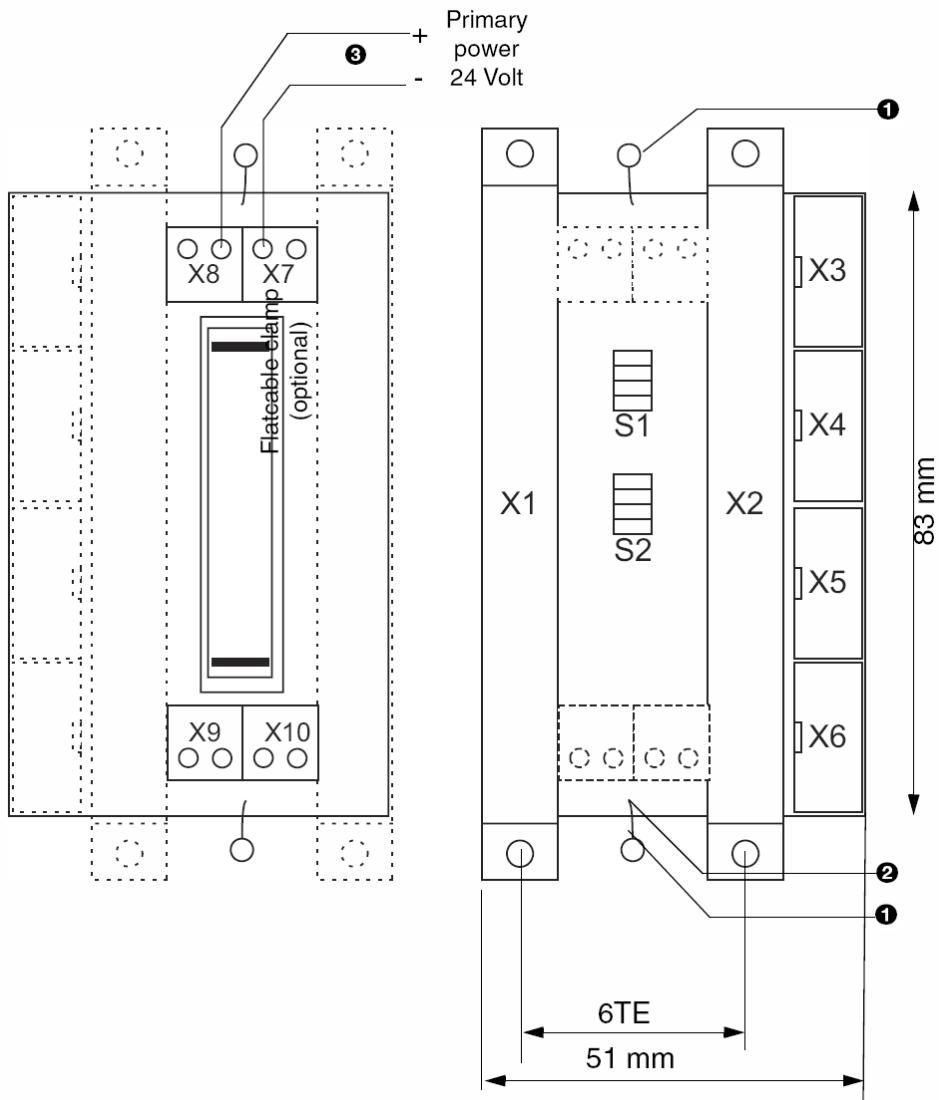

Figure 32 Connecting diagram SER I/O backplane

- Ground (**1**, **2**);
- I/O interfaces (X1, X2);
- RS485 interfaces (X3, X4);
- Looped Primary Power Input /Output from VECOM backplane (X7, X8) (**3**).

**Ground**

For EMC purposes connects the ground wires (**1**) of the backplane to the top and bottom rack mounting guides of the 3HE rack. If protective earth is required, solder a yellow-green wire (**2**) at the PCB spot above the terminal blocks X9, X10 and screw the other end with a cable to the rack.

**I/O interfaces**

The I/O interfaces will be made by the VCM module on DIN-C connector X1 and the VMM or VEM modules on connector X2 at the backplane.

X1, X2 (96 pole DIN-C)						
	A		B			C
Pin	Signal	Pin	Signal	Pin	Signal	
1	VP24	1	VP24	1	VP24	
2	VP24	2	VP24	2	VP24	
3	V00	3	V00	3	V00	
4	V00	4	V00	4	V00	
5	NC	5	NC	5	NC	
6	RxDA (ch 1)	6	V0_STDSE (ch 1)	6	TxDA (ch 1)	
7	RxDB (ch 1)	7	V0_STDSE (ch 1)	7	TxDB (ch 1)	
8	RxDA (ch 2)	8	V0_STDSE (ch 2)	8	TxDA (ch 2)	
9	RxDB (ch 2)	9	V0_STDSE (ch 2)	9	TxDB (ch 2)	
10	RESERVED	10	RESERVED	10	RESERVED	
11	RESERVED	11	RESERVED	11	RESERVED	
12	RESERVED	12	RESERVED	12	RESERVED	
13	RESERVED	13	RESERVED	13	RESERVED	
14	RESERVED	14	RESERVED	14	RESERVED	
15	RESERVED	15	RESERVED	15	RESERVED	
16	RESERVED	16	RESERVED	16	RESERVED	
17	RESERVED	17	RESERVED	17	RESERVED	
18	RESERVED	18	RESERVED	18	RESERVED	
19	RESERVED	19	RESERVED	19	RESERVED	
20	RESERVED	20	RESERVED	20	RESERVED	
21	RESERVED	21	RESERVED	21	RESERVED	
22	RESERVED	22	RESERVED	22	RESERVED	
23	NC	23	NC	23	NC	
24	NC	24	NC	24	NC	
25	V24_EXT	25	V24_EXT	25	V24_EXT	
26	V24_EXT	26	V24_EXT	26	V24_EXT	
27	V0_EXT	27	V0_EXT	27	V0_EXT	
28	V0_EXT	28	V0_EXT	28	V0_EXT	
29	NC	29	NC	29	NC	
30	GND	30	GND	30	GND	
31	GND	31	GND	31	GND	
32	GND	32	GND	32	GND	

Table 2 I/O Interfaces

### RS485 interfaces

X3 and X4 supply the RS485 interfaces for connection between VECOM backplane and I/O 1609/A or between VECOM backplane and the adjacent SER I/O backplane. Within the VECOM configuration the connectors X5 and X6 are not connected.

10 pole boxheader (male)			
X3		X4	
pin	signal	pin	signal
1	V0_STDSER	1	V0_STDSER
2	V0_STDSER	2	V0_STDSER
3	TxDB1 (output)	3	TxDB2 (output)
4	TxDA1 (output)	4	TxDA2 (output)
5	NC	5	NC
6	NC	6	NC
7	RxDB1 (input)	7	RxDB2 (input)
8	RxDA1 (input)	8	RxDA2 (input)
9	NC	9	NC
10	NC	10	NC

Table 3 RS485 Connections

### Primary Power Input /Output

Connect the primary output of the Power supply (PSU) or customer power to the terminal blocks X8 and X7 of the VECOM backplane at the rear of the rack.

Main connections			
X7		X8	
pin	Signal	pin	Signal
1	VP24	1	V00
2	VP24	2	V00

Table 4 Primary power input and output

If applicable, connect the power terminals of the VECOM backplane (Figure 31) to the power terminals of the SER I/O backplane (Figure 32).

### Secondary Power Input/output

Connect the secondary output of the Power supply (PSU) or customer power to the terminal blocks X9 and X10 of the VECOM backplane at the rear of the rack.

Main connections			
X9		X10	
Pin	Signal	Pin	Signal
1	VP24	1	V00
2	VP24	2	V00

Table 5 Secondary power input and output

If applicable, connect the Power loop cable to the terminal blocks X9 and X10 of the VECOM backplane at the rear of the rack. The Power loop cable may be used to power the IO1609/A modules and the LDP-T modules.

- It is preferable to keep the power connection to the LDP-T modules as short as possible.

## Dipswitches

The dipswitches on the backpanels have no function in the VECOM system.

## VECOM Control Module



Figure 33 Layout VECOM Control Module (VCM)

## Installation

1. Slide the VCM module over the PCB guides in the rack.
2. Secure the module with the screws at the front.

## Interfaces

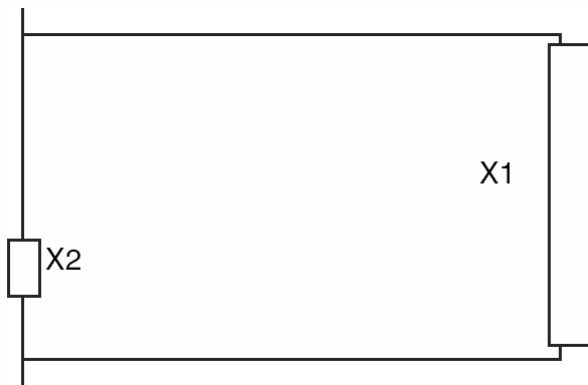

Figure 34 Connector positions VCM interface

- Diagnostic interface (X2);
- I/O Interface (X1).

### Diagnostic interface

The diagnostic interface defined as DIAG at the front of the VCM module has a 9 pins Sub-D connector with the following pinning:

X2 (9 pins Sub-D male)	
Pin	Signal
1	
2	RXD
3	TXD
4	
5	GND
6	
7	
8	
9	

Table 6 Diagnostic interface connections

**I/O Interface**

The I/O interfaces of the VCM module are connected to the backplane via a 96 pole DIN C connector male connector X1. This interface supports the power, synchronization and the VECOM transmit and receive signals.

<b>X1 (96 pole DIN-C male)</b>					
<b>A</b>		<b>B</b>		<b>C</b>	
Pin	Signal name	Pin	Signal name	Pin	Signal name
1	VSP24	1	VSP24	1	VSP24
2	VSP24	2	VSP24	2	VSP24
3	VS00	3	VS00	3	VS00
4	VS00	4	VS00	4	VS00
5	NC	5	NC	5	nc
6	RxDA (ch 1)	6	V0_STDSE (ch 1)	6	TxDA (ch 1)
7	RxDB (ch 1)	7	V0_STDSE (ch 1)	7	TxDB (ch 1)
8	RxDA (ch 2)	8	V0_STDSE (ch 2)	8	TxDA (ch 2)
9	RxDB (ch 2)	9	V0_STDSE (ch 2)	9	TxDB (ch 2)
10	GND (JTAG)	10	GND (JTAG)	10	GND (JTAG)
11		11		11	
12		12		12	
13	TDI (JTAG)	13	TMS (JTAG)	13	+3.3V (JTAG)
14	TDO (JTAG)	14	TCK (JTAG)	14	RST (JTAG)
15	VTRA0	15	VTRB0	15	GPIN0
16	VTRA1	16	VTRB1	16	GPIN1
17	VTRA2	17	VTRB2	17	GPIN2
18	VTRA3	18	VTRB3	18	GPIN3
19	VTRA4	19	VTRB4	19	GPOUT0
20	VTRA5	20	VTRB5	20	GPOUT1
21	VTRA6	21	VTRB6	21	SYNCREF
22	VTRA7	22	VTRB7	22	SYNCREF
23		23		23	
24		24		24	
25		25		25	
26		26		26	
27		27		27	
28		28		28	
29		29		29	
30	XGND	30	XGND	30	XGND
31	XGND	31	XGND	31	XGND
32	XGND	32	XGND	32	XGND

Table 7 VCM I/O Interface connection table



## LED indication

The eight leds at the front indicate the status of the corresponding VECOM loop:

- Off, the loop is not used;
- Fast flashing, the loop is operated;
- Slow flashing, the loop is defective;
- On, the loop is communicating;
- If all LED's are slow flashing, then the system is not running or all loops are defective.

## VECOM Modulator Module (VMM)



Figure 35 VECOM Modulator Module (VMM)

## Installation

1. Slide the VECOM Modulator Module (VMM) over the PCB guides in the rack and secure the module with the screws at the front;
2. Connect the interfaces:
  - 2x Loop 1...8 interface.

## Interfaces

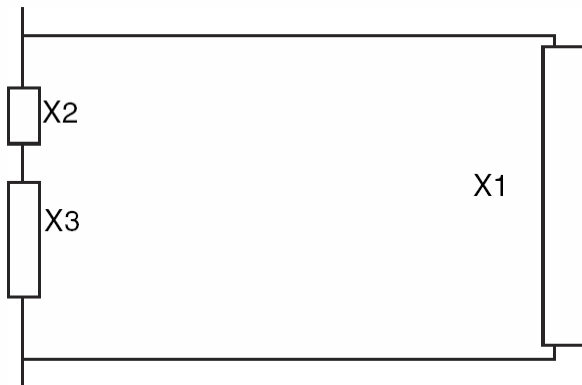

Figure 36 Connector positions VMM Interfaces

- Synchronization interface (X2);
- I/O Interface (X1);
- Loop 1...8 interface (X3).

### Synchronization interface

The 10 pole boxheader male X2 with lock mechanism supports the synchronization interface.

Pin	Signal name
1	GPIN0
2	GPIN1
3	GPIN2
4	GPIN3
5	GPOUT0
6	GPOUT1
7	SYNCREF
8	SYNCREF
9	SYNCREF
10	SYNCREF

Table 8 Synchronization interface connection table

### I/O Interface

The I/O interfaces of the VCM module are connected to the backplane via a 96 pole DIN C male connector X1. This interface supports power, synchronization and the VECOM transmit and receive signals.

X1 (96 pole DIN-C male)					
A		B		C	
Pin	Signal name	Pin	Signal name	Pin	Signal name
1	VSP24	1	VSP24	1	VSP24
2	VSP24	2	VSP24	2	VSP24
3	VS00	3	VS00	3	VS00
4	VS00	4	VS00	4	VS00
5		5		5	
6		6		6	
7		7		7	
8		8		8	
9		9		9	
10	GND (JTAG)	10	GND (JTAG)	10	GND (JTAG)
11		11		11	
12		12		12	
13	TDI (JTAG)	13	TMS (JTAG)	13	+3.3V (JTAG)
14	TDO (JTAG)	14	TCK (JTAG)	14	
15	VTRA	15	VTRB	15	GPIN0
16	TXCLKA	16	TXCLKB	16	GPIN1
17	CTRA	17	CTRB	17	GPIN2
18		18		18	GPIN3
19		19		19	GPOUT0
20		20		20	GPOUT1
21		21		21	SYNCREF
22		22		22	SYNCREF
23		23		23	
24		24		24	
25	V24_EXT	25	V24_EXT	25	V24_EXT
26	V24_EXT	26	V24_EXT	26	V24_EXT
27	V0_EXT	27	V0_EXT	27	V0_EXT
28	V0_EXT	28	V0_EXT	28	V0_EXT
29		29		29	
30	XGND	30	XGND	30	XGND
31	XGND	31	XGND	31	XGND
32	XGND	32	XGND	32	XGND

Table 9 VMM I/O Interface connection table

### Loop 1...8 interface

The eight loops are supported in a 25 pole Sub-D connector X3.

Pin	Signal name
1	TRA1
2	TRC1
3	V00B
4	TRA3
5	TRC3
6	V00B
7	TRA5
8	TRC5
9	V00B
10	TRA7
11	TRC7
12	V00B
13	V00B
14	TRA2
15	TRC2
16	V00B
17	TRA4
18	TRC4
19	V00B
20	TRA6
21	TRC6
22	V00B
23	TRA8
24	TRC8
25	V00B

Table 10 VMM Loop connection table

## VECOM Extension Module (VEM)



Figure 37 VECOM Extension Module (VEM)

### Installation

1. Slide the VECOM Extension Module (VEM) over the guides in the rack and secure the module with the screws at the front.
2. Connect the interfaces:
  - Synchronization interface;
  - Loop interfaces (2x).

### Interfaces

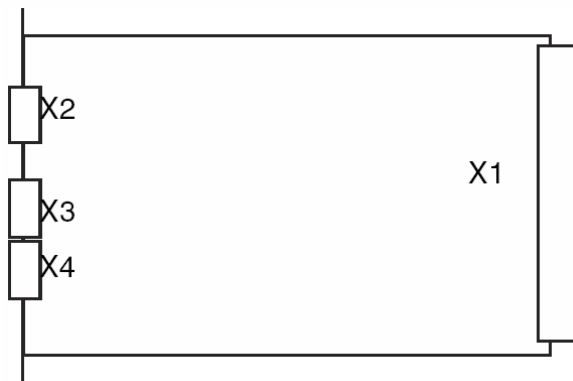

Figure 38 Connector positions VEM Interfaces

- Synchronization interface (X2);
- I/O interface (X1);
- Loop interfaces (X3, X4).

**Synchronization interface**

The 10 pole boxheader male X2 with lock mechanism supports the synchronization interface.

Pin	Signal name
1	GPIN0
2	GPIN1
3	GPIN2
4	GPIN3
5	GPOUT0
6	GPOUT1
7	SYNCREF
8	SYNCREF
9	SYNCREF
10	SYNCREF

Table 11 VEM Synchronization interface connection table

**I/O interface**

The I/O interfaces of the VEM module are connected to the backplane via a 96 pole Din C male connector X1. This interface supports power, synchronization and the VECOM transmit and receive signals.

A		B		C	
Pin	Signal name	Pin	Signal name	Pin	Signal name
1		1		1	
2		2		2	
3		3		3	
4		4		4	
5		5		5	
6		6		6	
7		7		7	
8		8		8	
9		9		9	
10		10		10	
11		11		11	
12		12		12	
13		13		13	
14		14		14	
15	VTRA0	15	VTRB0	15	GPIN0
16	VTRA1	16	VTRB1	16	GPIN1
17	VTRA2	17	VTRB2	17	GPIN2
18	VTRA3	18	VTRB3	18	GPIN3
19	VTRA4	19	VTRB4	19	GPOUT0
20	VTRA5	20	VTRB5	20	GPOUT1
21	VTRA6	21	VTRB6	21	SYNCREF
22	VTRA7	22	VTRB7	22	SYNCREF
23	VTRA0	15	VTRB0	23	
24		24		24	
25		25		25	
26		26		26	
27	VTRREF	27	VTRREF	27	VTRREF
28	VTRREF	28	VTRREF	28	VTRREF
29		29		29	
30	XGND	30	XGND	30	XGND
31	XGND	31	XGND	31	XGND
32	XGND	32	XGND	32	XGND

Table 12 VEM I/O Interface connection table

### Loop interfaces

The front of the VEM module facilitates two identical loop interfaces with a 10 pole box header male, both connectors X3 and X4 can support four loops.

X3	
Pin	Signal name
1	VTRA0
2	VTRB0
3	VTRA1
4	VTRB1
5	VTRA2
6	VTRB2
7	VTRA3
8	VTRB3
9	VTRAREF
10	VTRAREF

Table 13 VEM Loop Interface connection table (X3)

X4	
Pin	Signal name
1	VTRA4
2	VTRB4
3	VTRA5
4	VTRB5
5	VTRA6
6	VTRB6
7	VTRA7
8	VTRB7
9	VTRAREF
10	VTRAREF

Table 14 VEM Loop Interface connection table (X4)



## 7 Intra-cabinet system connections

### General

The additional hardware for VECOM systems consists of:

- Rack related hardware:
  - Power supply (PSU);
  - SER I/O Module.
- Mounting rail related hardware:
  - Loop Distribution Panel/Wide Style (LDP/WS),
  - Loop Distribution Panel-T (LDP-T),
  - I/O 1609/A Module.
- Interconnection cables:
  - Power loop cable,
  - RS232 interface.

### Power supply (PSU) Power One



Figure 39 Power Supply

### Installation

1. Mount the power connector at the rear of the rack according the configuration plan;
2. Install the PCB guides in front of the rear connector in the rack;
3. Connect mains and output power, the rack must be connected to the safety earth;
4. Slide the PSU over the guides in the rack and secure the module with the screws at the front.

### Interfaces

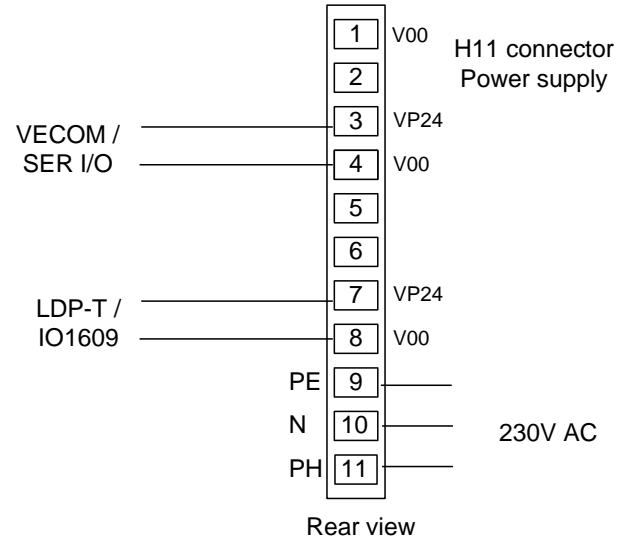

Figure 40 Connection diagram Power supply (PSU) interfaces

Pin PSU	Pin rear connector	Cable colour	Signal
2	1	White	V00 (looped to pin 9)
5	2		
8	3	Brown	VP24 (VECOM C/CT / SER I/O)
11	4	White	V00 (VECOM C/CT / SER I/O)
14	5		
17	6		
20	7	Brown	VP24 (LTP-T and/or IO 1609/A)
23	8	White	V00 (LTP-T and/or IO 1609/A)
26	9	Yellow/green	Safety Earth
29	10	Blue	Neutral
32	11	Brown	Phase

Table 15 Power supply (Power One) unit connection table

## Power supply (PSU) MGV



### Installation

1. Mount the power connector at the rear of the rack according the configuration plan;
2. Install the PCB guides in front of the rear connector in the rack;
3. Connect mains and output power, the rack must be connected to the safety earth;
4. Slide the PSU over the guides in the rack and secure the module with the screws at the front.

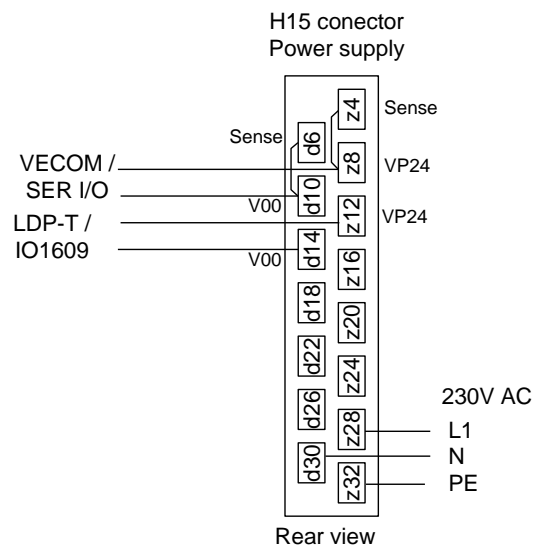

Pin rear connector	Cable colour	Signal
Z4	Brown	Sense +
D6	White	Sense -
Z8	Brown	VP24 (VECOM C/CT / SER I/O)
D10	White	V00 (VECOM C/CT / SER I/O)
Z12	Brown	VP24 (LTP-T and/or IO 1609/A)
D14	White	V00 (LTP-T and/or IO 1609/A)
Z16		
D18		
Z20		
D22		
Z24		
D26		
Z28	Brown	Phase
D30	Blue	Neutral
Z32	Yellow/green	Safety Earth

Table 16 Power supply (MGV) unit connection table

## SER I/O Module

The SER I/O module can convert serial channels of VECOM-Compact to one of the following interfaces:

- RS485 half-duplex (two wire);
- RS485 full-duplex (four wire);
- RS232.

The distribution of those signals is done with the Backplane I/O which supports two SER I/O modules.



Figure 41 SER I/O Module

1. Mount a second Backplane at the rear of the rack according the configuration plan to support the SER I/O modules (see the paragraph "Backplane");
2. Slide the SER I/O module over the PCB guides in the rack and secure the module with the screws at the front;
3. Connect the required RS485 interfaces (channel 1 and/or 2) with a 10 pole crossed flat cable from the Backplane at the VECOM system to the Backplane of the SER I/O module;
4. Connect the supported RS232 interfaces (channel 1 - X1 and/or 2 -X3) at the front side of the SER I/O.

### Interfaces

The SER I/O is supplied with 24 VDC on the second backplane which is looped via the backplane of the VECOM system.

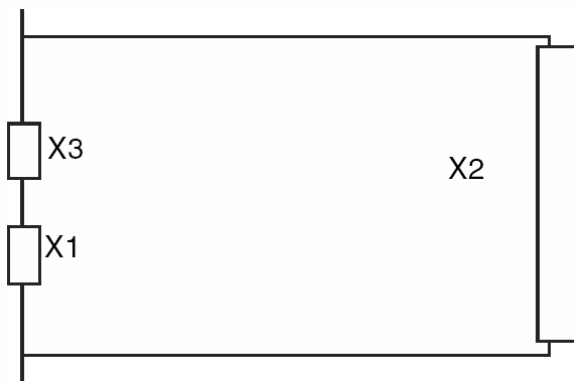

Figure 42 Connector diagram SER I/O

- I/O interface (X2);
- RS232 Interface (channel 1 = X1, channel 2 = X3).

**I/O interface**

The I/O interface of the SER I/O module is connected to the backplane via a 96 pole DIN C male connector X1. This interface supports the power, synchronization and the VECOM transmit and receive signals.

X2 (96 pole DIN-C male)					
A		B		C	
Pin	Signal name	Pin	Signal name	Pin	Signal name
1	VSP24	1	VSP24	1	VSP24
2	VSP24	2	VSP24	2	VSP24
3	VS00	3	VS00	3	VS00
4	VS00	4	VS00	4	VS00
5		5		5	
6	RXDA1	6	VO_STDSE	6	TXDA1
7	RXDB1	7	VO_STDSE	7	TXDB1
8	RXDA2	8	VO_STDSE	8	TXDA2
9	RXDB2	9	VO_STDSE	9	TXDB2
10	GND (JTAG)	10	GND (JTAG)	10	GND (JTAG)
11		11		11	
12		12		12	
13		13		13	
14		14		14	
15		15		15	
16		16		16	
17		17		17	
18		18		18	
19		19		19	
20		20		20	
21		21		21	
22		22		22	
23		23		23	
24		24		24	
25		25		25	
26		26		26	
27		27		27	
28		28		28	
29		29		29	
30	XGND	30	XGND	30	XGND
31	XGND	31	XGND	31	XGND
32	XGND	32	XGND	32	XGND

Table 17 SER I/O Interface connection table

### RS232 Interface

The external RS232 interfaces, channel 1 and 2 of SER I/O module, both have a 9 pin Sub-D connector. The signals in the connector use the following pinning:

X1 and X3 (9 pins Sub-D female)				
Pin	Signal			
	RS485 duplex	half	RS485 duplex	full RS232
1				
2				TxD (output)
3	TXDB / RXDB		TXDB	RxD (input)
4	TXD		RXDB	
5	DATA GND		DATA GND	DATA GND
6				
7				
8	TXDA / RXDA		TXDA	
9			RXDA	
shell	XGND		XGND	XGND
RXDA RXDB TXDA TXDB DATA GND RXD TXD XGND	RS485 receive signal input A RS485 receive signal input B RS485 transmit signal output A RS485 transmit signal output B signal ground RS232 receive signal input RS232 transmit signal output System ground, normally connected to cable screen			

Table 18 SER I/O RS232 Interface connection table

### Dipswitches and installation position

The following tables give the jumper setting of each channel and the installation location on the RS485 bus cable for:

- Bus termination;
- RS485 half duplex (two wire);
- RS485 full duplex (four wire);
- RS232.

**Bus termination**

Both far ends of an RS485 bus should be terminated with a resistor, this may be an external resistor or the built in resistors of the SER I/O. The built in damping circuit holds the bus in passive state when floating.

Channel 1	Jumper layout	Channel 2
J1-1 = 200 ohm termination to 3.3 V		J4-1 = 200 ohm termination to 3.3 V
J1-2 = 200 ohm termination to ground		J4-2 = 200 ohm termination to ground
J1-3		J4-3
J1-4		J4-4
J2-1		J5-1
J2-2		J5-2
J2-3		J5-3
J2-4		J5-4
J3-1		J6-1
J3-2		J6-2
J3-3		J6-3
J3-4		J6-4

Table 19 RS485 Bus termination

**Half duplex**

Channel 1	Jumper layout	Channel 2
J1-1		J4-1
J1-2		J4-2
J1-3		J4-3
J1-4		J4-4
J2-1		J5-1
J2-2		J5-2
J2-3 = RxDB		J5-3 = RxDB
J2-4 = RxDA		J5-4 = RxDA
J3-1 = connect RxDA with TxDA		J6-1 = connect RxDA with TxDA
J3-2 = connect RxDA with TxDB		J6-2 = connect RxDA with TxDB
J3-3		J6-3
J3-4		J6-4

Table 20 RS485 Bus half duplex jumper configuration



**Full Duplex**

Channel 1	Jumper layout	Channel 2
J1-1	<div style="display: flex; align-items: center; justify-content: center;"> <div style="margin-right: 10px;">▪</div> <div style="display: flex; flex-direction: column; align-items: center;"> <div style="margin-bottom: 10px;">J1 / J4</div> <div style="margin-bottom: 10px;">J2 / J5</div> <div style="margin-bottom: 10px;">J2 / J6</div> </div> <div style="margin-left: 10px;">□</div> </div>	J4-1
J1-2		J4-2
J1-3		J4-3
J1-4 = Auto enable off		J4-4 = Auto enable off
J2-1 = TxDB		J5-1 = TxDB
J2-2 = TxDA		J5-2 = TxDA
J2-3 = TxDB		J5-3 = TxDB
J2-4 = RxDA		J5-4 = RxDA
J3-1		J6-1
J3-2		J6-2
J3-3		J6-3
J3-4		J6-4

Table 21 RS485 Bus full duplex jumper configuration

**RS232**

Channel 1	Jumper layout	Channel 2
J1-1	<div style="display: flex; align-items: center; justify-content: center;"> <div style="margin-right: 10px;">▪</div> <div style="display: flex; flex-direction: column; align-items: center;"> <div style="margin-bottom: 10px;">J1 / J4</div> <div style="margin-bottom: 10px;">J2 / J5</div> <div style="margin-bottom: 10px;">J2 / J6</div> </div> </div>	J4-1
J1-2		J4-2
J1-3		J4-3
J1-4		J4-4
J2-1		J5-1
J2-2		J5-2
J2-3		J5-3
J2-4		J5-4
J3-1		J6-1
J3-2		J6-2
J3-3 = RxD		J6-3 = RxD
J3-4 = TxD		J6-4 = TxD

Table 22 RS232 Jumper Configuration

## Mounting rail

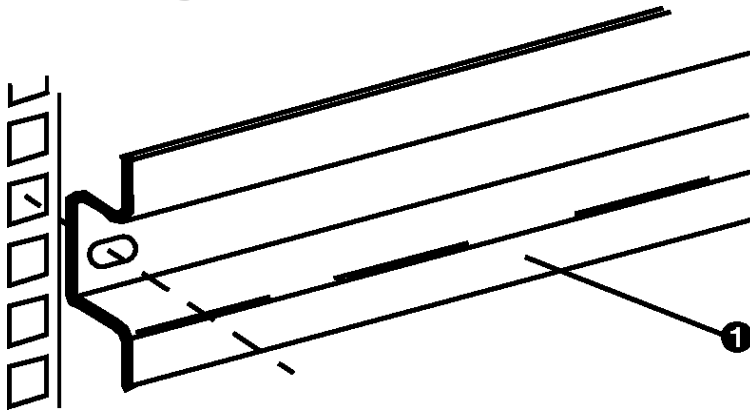

Figure 43 Mounting rail

Take the following steps to mount the mounting rail in the cabinet to support loop distribution panels (LDP/WS and LDP-T) and I/O 1609/A Module:

1. Define the position of the mounting rail within 1.5 m from the VECOM System. The rail mounting position must use the same grounding point as the VECOM system;
2. Screw the mounting rail to both cabinet supports with the proper fastening materials of the cabinet.

## Loop Distribution Panel/Wide Style (LDP/WS)

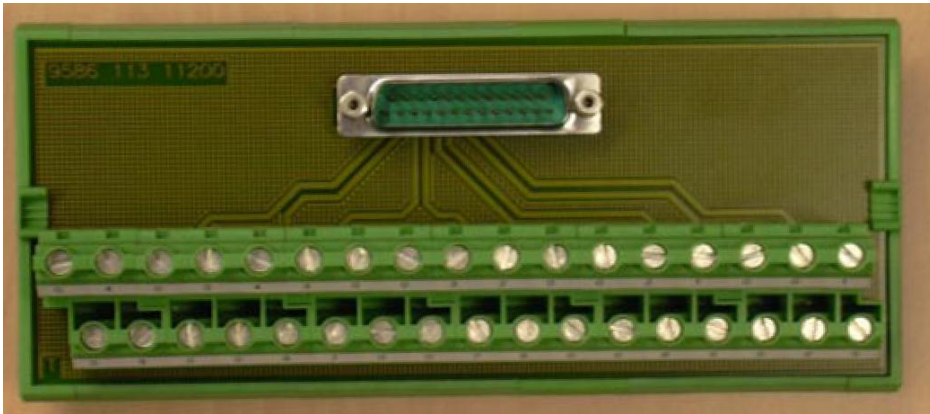

Figure 44 Loop distribution Panel/Wide Style (LDP/WS)

### Installation

Proceed with the following steps to install the LDP/WS:

1. Install the Mounting rail (see the paragraph above) within 1.5 m from the VECOM system;
2. The LDP/WS must be clicked with a rolling movement from bottom to top on a Mounting rail;
3. Connect the signal cables to the VECOM configuration and the feeder cables to the Loop Buffer.

### Interfaces

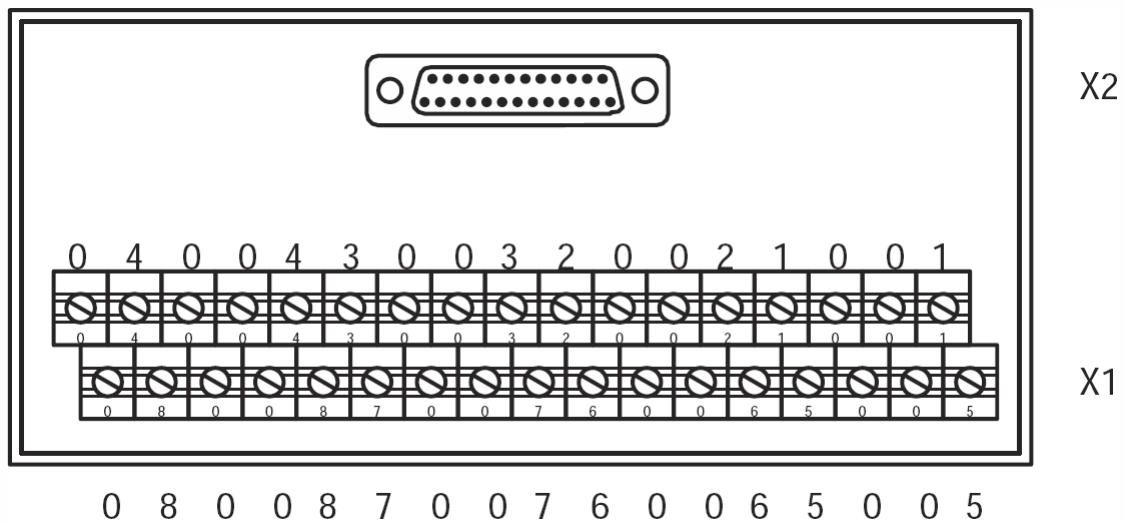
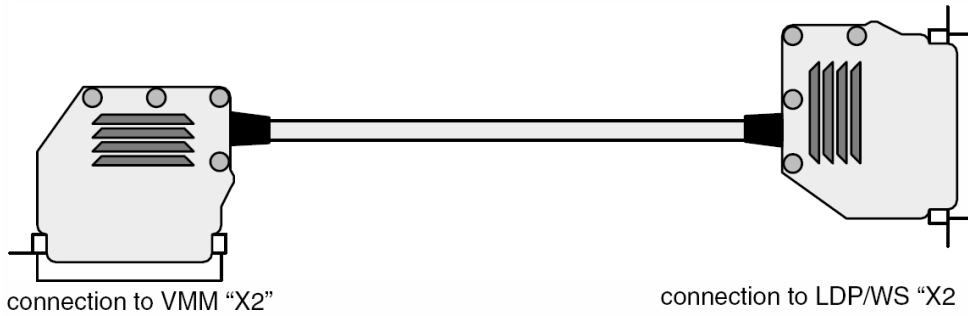

Figure 45 LDP/WS schematic

- Loop distribution cable interface (X2);
- Feeder cable interface (X1).

**Loop distribution cable interface**

The loop distribution cable interconnects the LDP/WS with the VMM via the Backplane of the VECOM system (see chapter 6 "Backplane").



25 pin male  
routed to VMM "X2"

25 pin female connector  
routed to LDP/WS "X2"

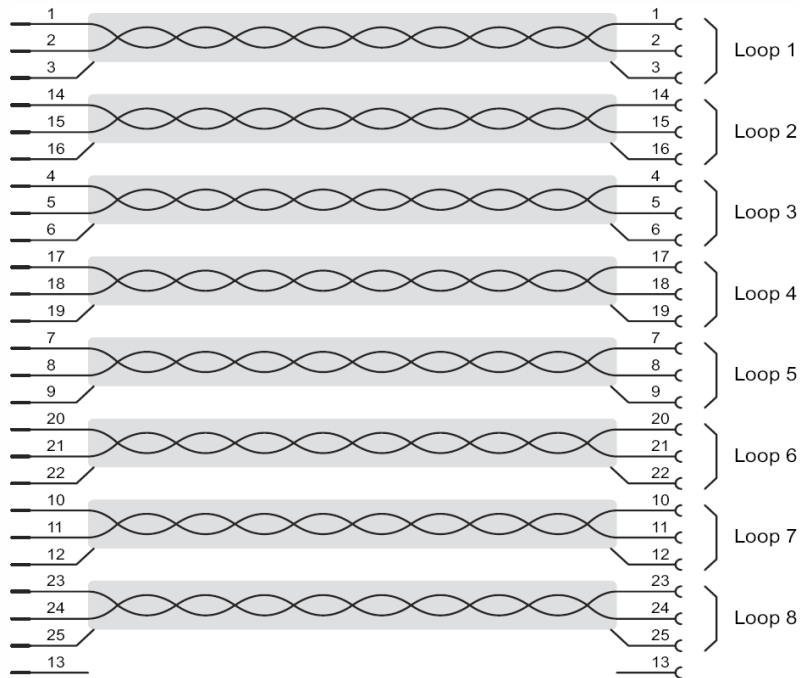

Figure 46 Loop distribution cable and pinning

**Feeder cable interface**

The feeder cable connects the LDP/WS and the Loop Buffer (LB), see paragraph 'Loop Module'.

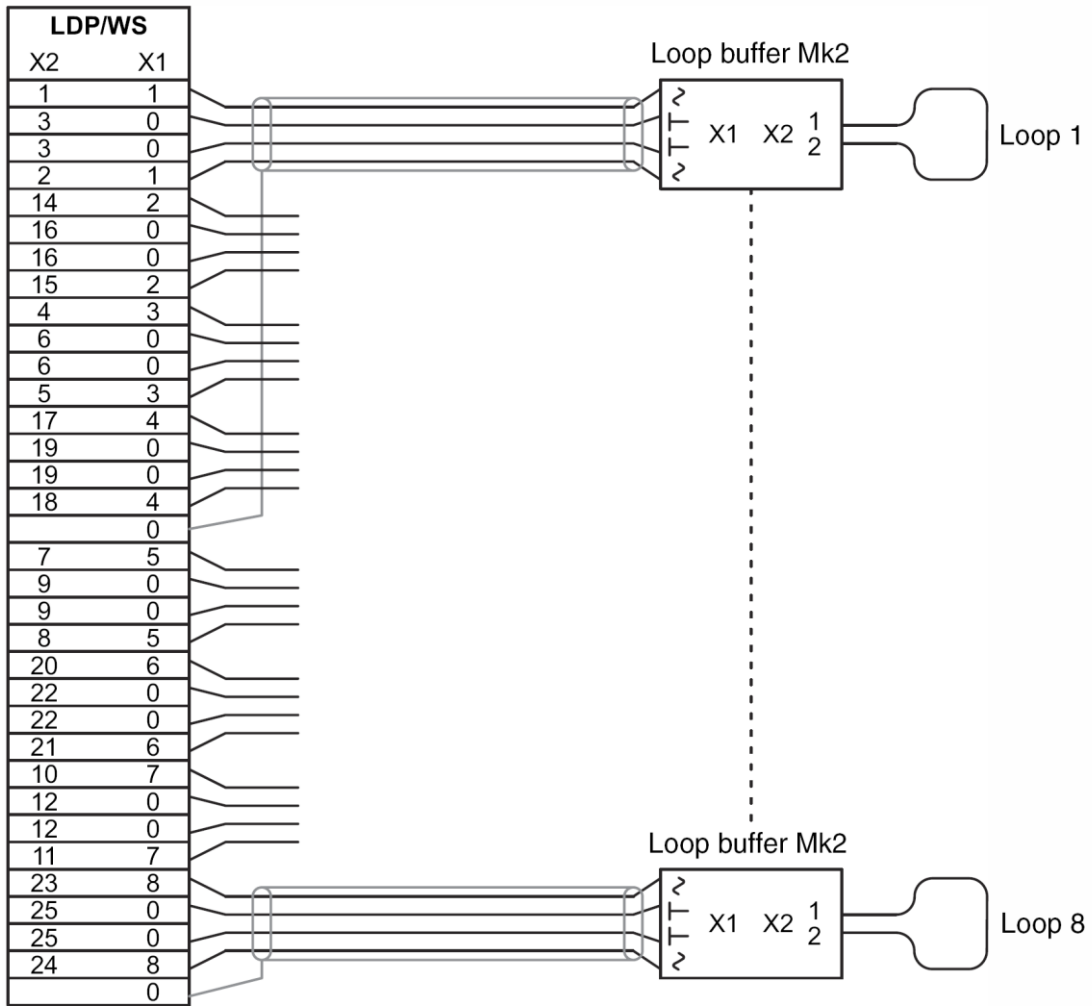

Figure 47 LDP/WS pinning

The screen of the feeder cable must be connected to the mounting rail where the cable enters the cabinet.



## Loop Distribution Panel-T (LDP-T)



Figure 48 Loop distribution panel (LDP-T)

### Installation

Proceed with the following steps to install the LDP-T:

1. Install the Mounting rail (see section 7.4) within 1.5 m from the VECOM system;
2. The Loop distribution panel (LDP-T) must be clicked with a rolling movement from bottom to top on a Mounting rail;
3. Supply the power with one of the first connectors of the power loop cable to the LDP-T;
4. Connect the signal cables to the VECOM configuration and the feeder cables to the Loop Buffer.

### Interfaces

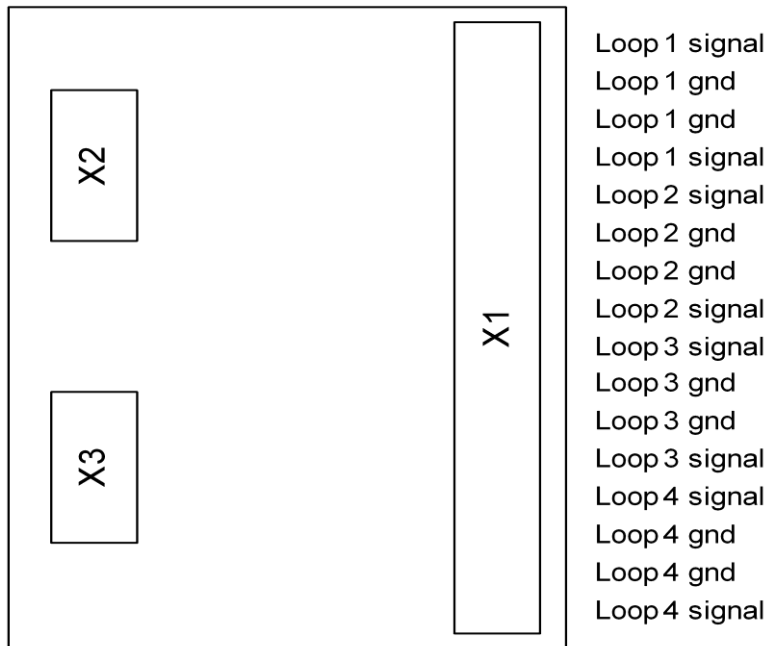

Figure 49 LDP-T Schematic

- power input interface (X3);
- loop Distribution cable interface (X2);
- Loop Transceiver interface (X1).

#### Power input interface

Both LDP-T panels are supplied with 24V DC by the first and second connector of the Power loop cable. These connectors must be connected to the X3 connector on the LDP-T panel.

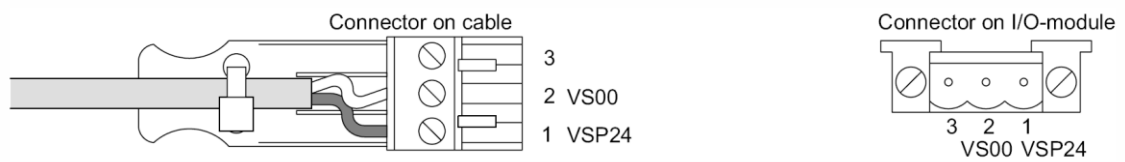

Figure 50 24V Power input

**Loop Distribution cable interface**

The loop distribution cable is a 10 pole flat cable that interconnects the Loop distribution panel (LDP-T) via X2 with the VEM via the Backplane of the VECOM system.

X2	
Pin	Signal name
1	VTRA0
2	VTRB0
3	VTRA1
4	VTRB1
5	VTRA2
6	VTRB2
7	VTRA3
8	VTRB3
9	VTRAREF
10	VTRAREF

Table 23 Loop distribution cable interface

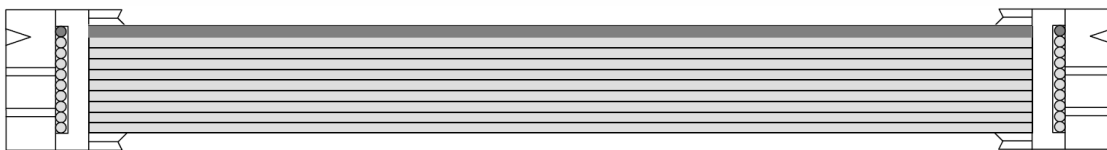

10 pole boxheader  
routed to VEM "X3 or X4"

10 pole boxheader  
routed to LDP-T "X2"

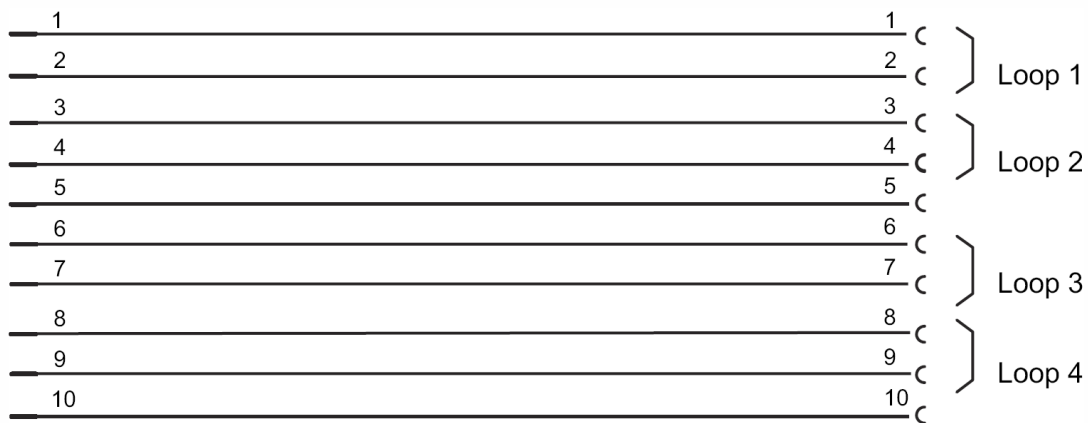

Figure 51 Layout flatcable



**Loop Transceiver interface**

The Loop Transceiver cable is the connection between the Loop interface distribution panel (LDP-T) via X1 connector and the Loop Transceiver (LT), see paragraph 'Loop Module'. The cable shielding must be connected to '⊥'.

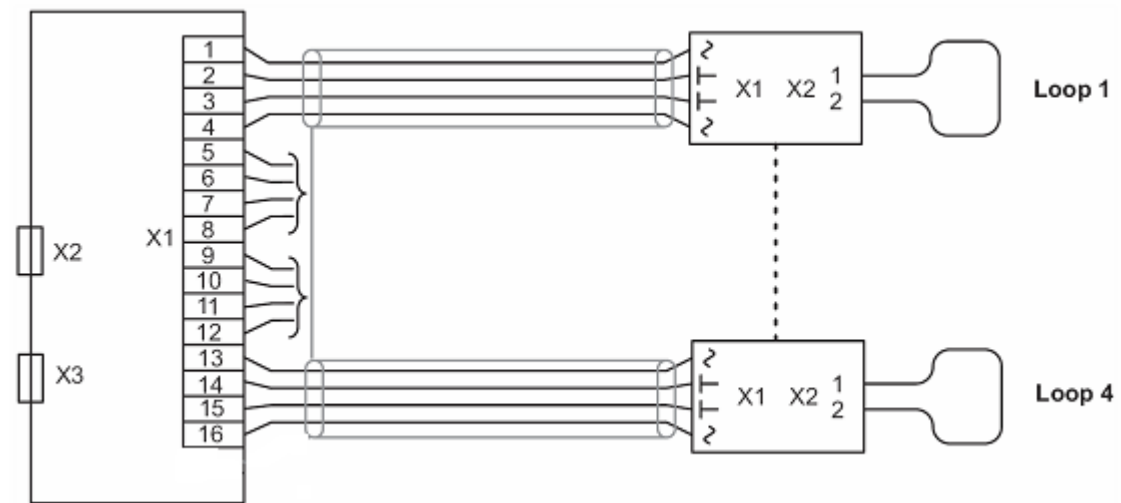

Figure 52 LDP-T pinning

The screen of the feeder cable must be connected to the mounting rail where the cable enters the cabinet:



## I/O 1609/A Module

The I/O-1609A is a module which can read 16 parallel inputs and control 8 parallel outputs. The inputs are galvanically isolated by means of opto-couplers. The outputs are isolated by means of relays.

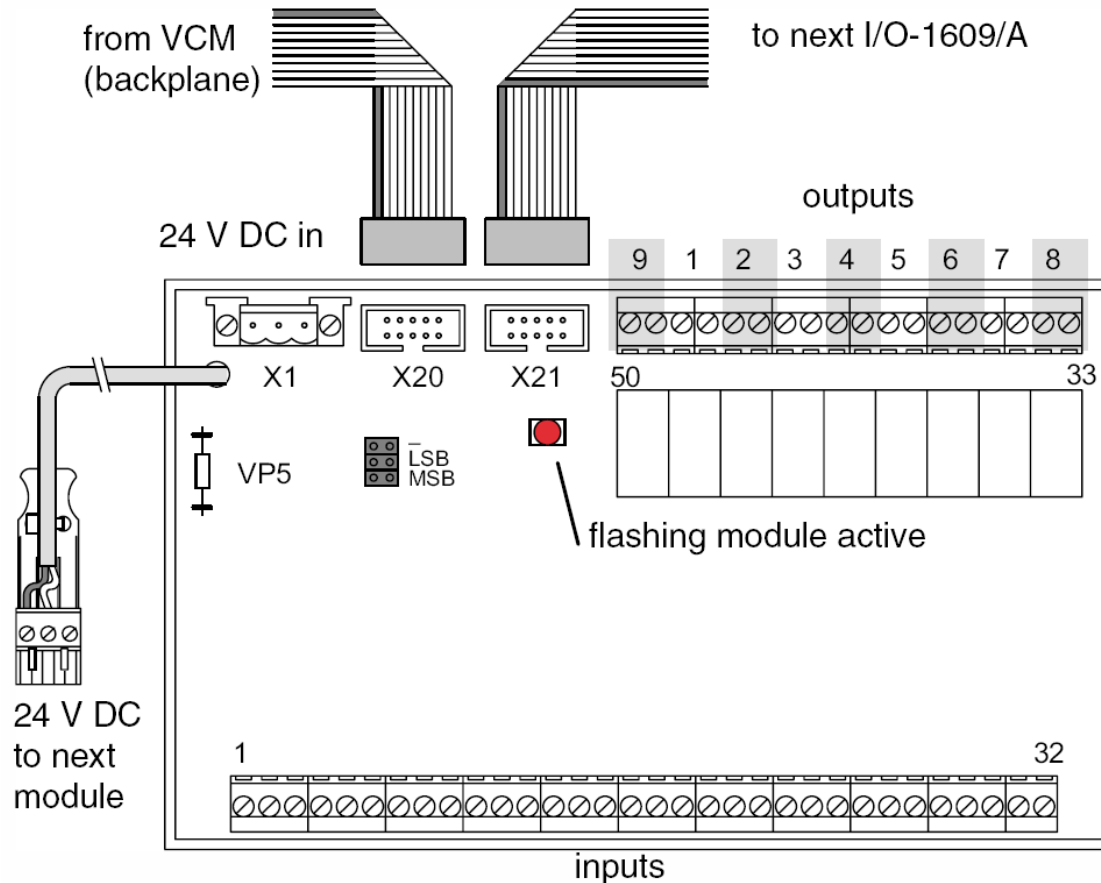

Figure 53 Layout I/O 1609/A Module

## Installation

1. Click the I/O 1609/A Module with a rolling movement from bottom to top on a Mounting rail within 1.5 m from the VECOM system;
2. If more than one IO1609 modules are used select the correct unit address for the second module as described below;
3. Connect the interface as described in the next paragraph:
  - Power input interface (X1) and loop cable;
  - Multi drop serial link interface (X20) and (X21);
  - Parallel input interface (1...32);
  - Parallel output interface (33...50);
4. Route and dress the cables properly to the cabinet.



### CAUTION

To prevent electromagnetic interference do not route any cabling over or under the IO1609 module.

## Interfaces

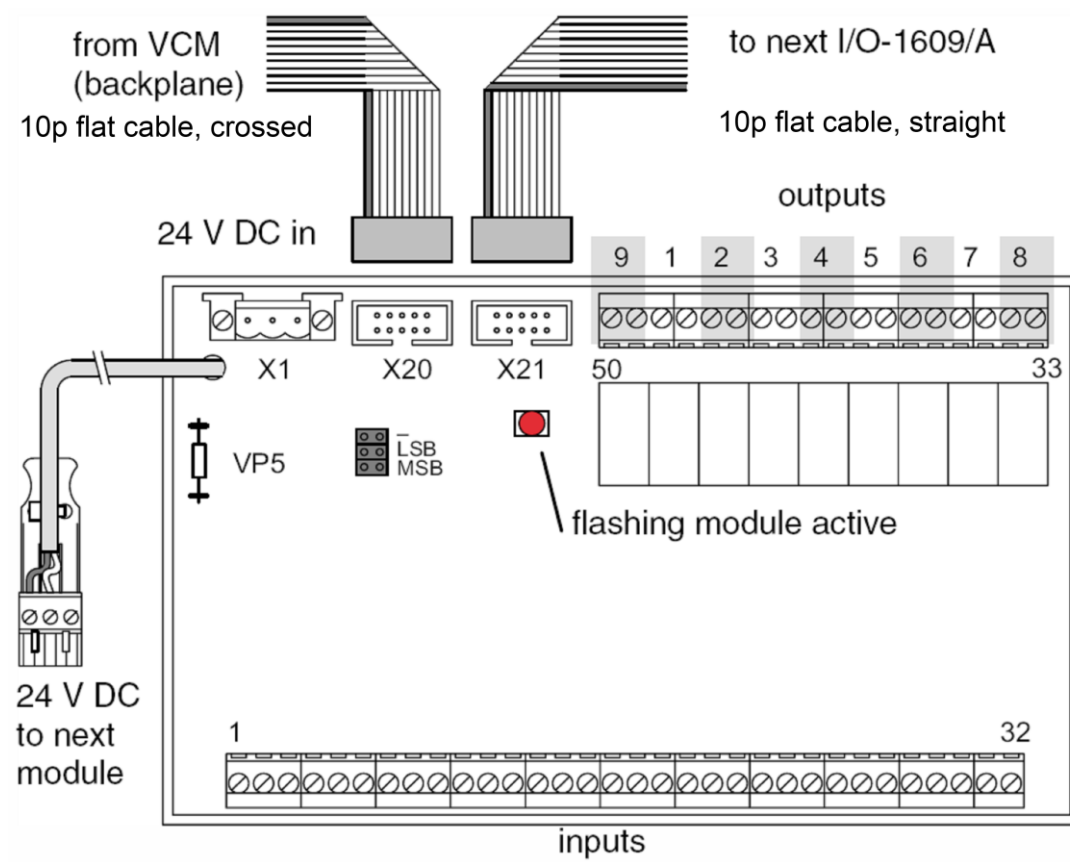

Figure 54 I/O 1609/A Module

- Power input interface (X1) Multi drop;
- Serial link interface (X20, X21) Serial;
- Input interface (1...32) Parallel input;
- Interface (33...50) Output.

### Power input interface

The first I/O 1609/A module is supplied with 24V DC by the third connector of the Power loop cable (see paragraph "Power Loop Cable"). This connector must be connected to the X1 connector on the I/O 1609/A module. The second I/O 1609/A module should use the provided cable of the first I/O 1609/A module.

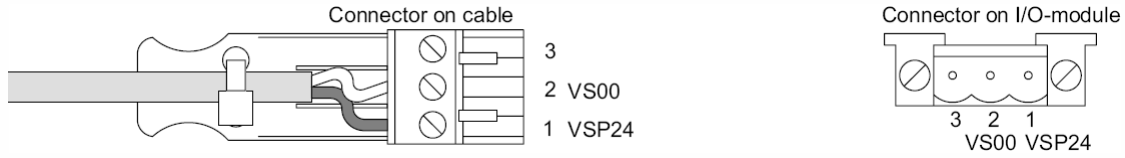

Figure 55 Power and powerloop of 24V

### Multi drop serial link interface

The I/O-1609A can be connected to a multi drop serial link (RS485) of the VCM module on the backplane using a 10 pole crossed flat cable, see 'RS485 interfaces'. The multi drop serial channel is connected to X20, and looped through to the next I/O-1609A via X21 using a straight 10 pole flat cable. The signals on X20/X21 are looped through and connected to the logic circuits of the unit.

X20		X21	
Pin	Signal	Pin	Signal
1	V0_STDSER	1	V0_STDSER
2	V0_STDSER	2	V0_STDSER
3	TxDB# (output)	3	TxDB# (output)
4	TxDA# (output)	4	TxDA# (output)
5	NC	5	NC
6	NC	6	NC
7	RxDB# (input)	7	RxDB# (input)
8	RxDA# (input)	8	RxDA# (input)
9	NC	9	NC
10	NC	10	NC

Table 24 Multi drop serial link (RS485) connection table



Figure 56 Cable from backpanel to I/O1609/A



Figure 57 Cable between two I/O1609/A units

**Parallel input interface**

The input interface circuits are galvanically isolated from the logic circuits.

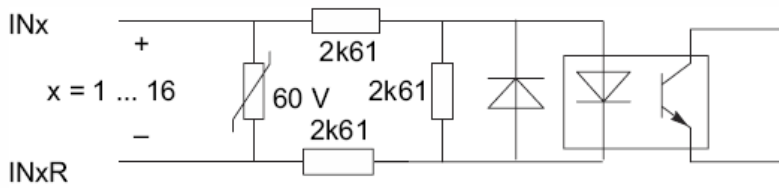

Figure 58 Parallel input interface of I/O-1609/A

input circuits			
Terminal pin I/O-1609A	Signal name input circuits	Terminal pin I/O-1609A	Signal name input circuits
1	IN1	17	IN9
2	IN1R	18	IN9R
3	IN2	19	IN10
4	IN2R	20	IN10R
5	IN3	21	IN11
6	IN3R	22	IN11R
7	IN4	23	IN12
8	IN4R	24	IN12R
9	IN5	25	IN13
10	IN5R	26	IN13R
11	IN6	27	IN14
12	IN6R	28	IN14R
13	IN7	29	IN15
14	IN7R	30	IN15R
15	IN8	31	IN16
16	IN8R	32	IN16R

Table 25 Parallel input I/O 1609/A connection table

**Parallel output interface**

The output circuits are isolated from the logic circuits by means of a relay.

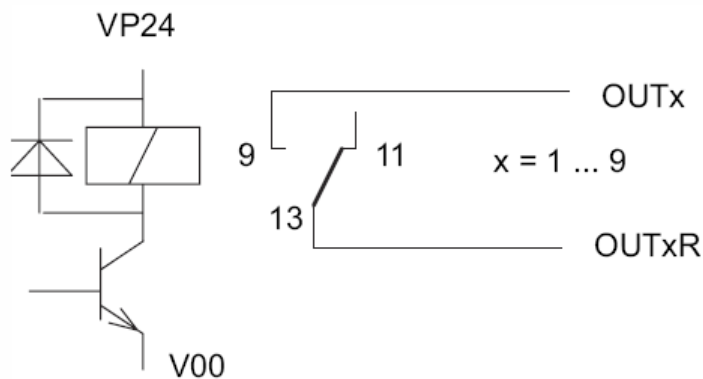

Figure 59 Parallel output circuit of the I/O-1609/A

output circuits	
Terminal pin I/O-1609A	Signal name output circuits
8 (33)	OUT8R
8 (34)	OUT8
7 (35)	OUT7R
7 (36)	OUT7
6 (37)	OUT6R
6 (38)	OUT6
5 (39)	OUT5R
5 (40)	OUT5
4 (41)	OUT4R
4 (42)	OUT4
3 (43)	OUT3R
3 (44)	OUT3
2 (45)	OUT2R
2 (46)	OUT2
1 (47)	OUT1R
1 (48)	OUT1
9 (49)	OUT9R
9 (50)	OUT9

Table 26 Parallel output I/O 1609/A connection table

### Led indication

The LED's at the PCB indicate the status and indicate the following three states:

- LED flashing fast: normal state;
- LED continuous on or off: the unit is not active and/or the VP5 supply is defect;
- LED is approx. 0.5...1 second per 15 seconds on: there is no communication with the VCM.

### Jumpers

The address jumpers setting are the following order.

Address jumpers		Communication identification	
1		LSB	module 1
2		MSB	
1		LSB	module 2
2		MSB	
	No jumper		Jumper placed

Table 27 I/O 1609/A Address jumper settings

### Power loop cable

The Power loop cable supplies the 24 VDC from one of the Backplanes to the LDP-T panels and/or the I/O 1609/A modules.

The open end must be connected with fastons to the Backplane. The connections within the configurations of the Combicon connectors are are:

- VECOM-CT configuration:  
The first two connectors are reserved for the Loop Distribution Panel-T (LDP-T), see the previous paragraph. The last connector must connected to the first I/O 1609/A module.
- VECOM-C configuration:  
The first two connectors are reserved and must be isolated. The last connector must connected the first I/O 1609/A module.

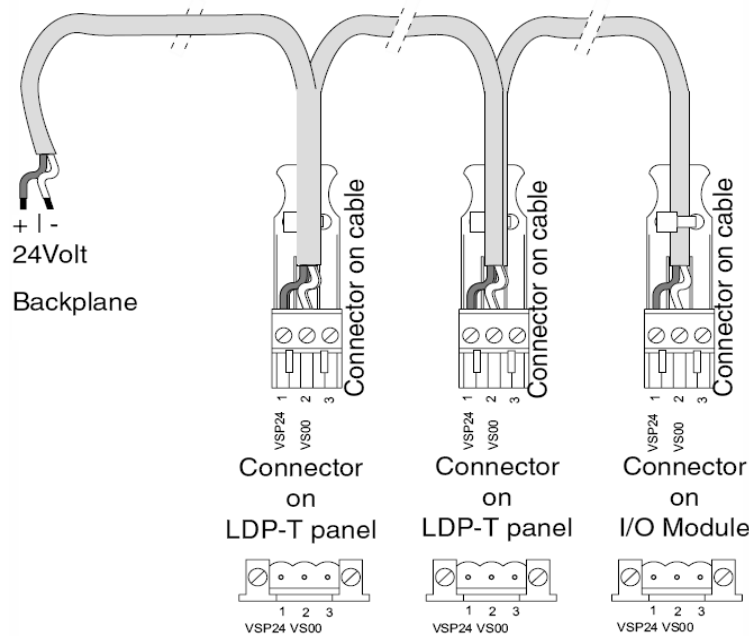

Figure 60 Layout power cable





## 8 Synchronization of VECOM systems

When the loops of two VECOM systems are located in each others neighbourhood some extra measures must be taken to prevent mutual interference. The involved loops are configured for exclusive or synchronous interrogation.

### Synchronous interrogation

In synchronous interrogation mode, loops of two VECOM systems are interrogated simultaneously. If loops of different VECOM systems are located within a distance of 20 meters, the signals from these loops may affect each other in a negative way. These loops can be interrogated synchronously to prevent this. Synchronous interrogation can be applied for two or more VECOM systems.

Synchronous interrogations can be enabled by configuring the multiplexer control table after which a connection between VECOM systems must be made (see below).

### Exclusive interrogation

In exclusive interrogation mode, one VECOM system must complete the interrogation of a loop before the other VECOM system can interrogate a loop. If loops of different VECOM systems are located within a distance of 4 meters, and a vehicle can be detected by both VECOM systems at the same time. Exclusive interrogation prevents a vehicle from being detected by both VECOM systems at the same time.

Synchronous interrogations can be enabled by configuring the multiplexer control table after which a connection between VECOM systems must be made (see below).

## Connection

The synchronization interfaces (X2 on VMM or VEM) of the two VECOM must be interconnected. The interfaces are not galvanically isolated which means that only VECOM systems which are mounted in the same cabinet can be synchronized.

The connection between the VECOM synchronisation interfaces is as follows:

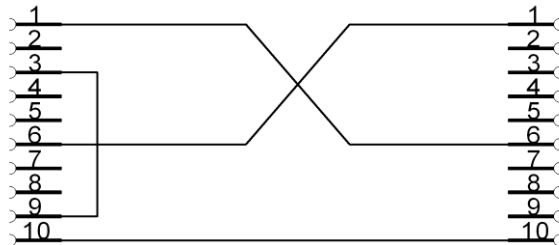

Figure 61 Connection between VECOM systems for synchronisation between two stations

There is a way to synchronise between more than two stations but *in exclusive mode only*, the required connection is as follows:

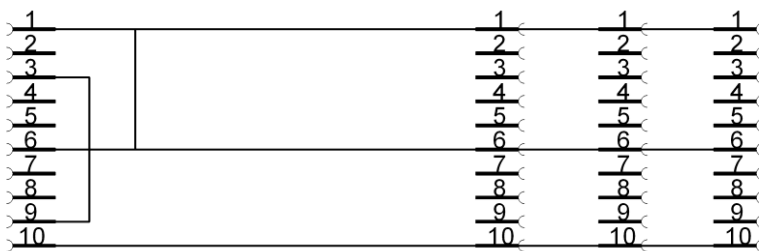

Figure 62 Connection between VECOM systems for synchronization between more than two stations

## 9 Testing

The functional performance of the loop can be tested after connection to a VECOM system:

1. Connect a portable PC to the VECOM configuration DIAG port;
2. Start the WDMT program on the PC (see Related documentation);
3. Test the communications with a VETAG test transponder:  
For this measurement, the test transponder must be held at a height of 1.0 m above the loop (0.75 m for loops between tram-rail). There must then be a response on the PC monitor and also via the corresponding loop status LED on the VCM;

Be sure that for this test the loaded MUX table is suitable for VETAG/VECOM;

4. When relay contacts are used for connection to other systems, their proper functioning is tested by adjusting the required vehicle ID at the test transponder.

If a VECOM system is to communicate with a traffic control system, its proper operation must be checked.

In the event that the VCM receives a signal while the corresponding loop LED is unstable, this can be attributed to interference picked up.



## 10 Appendix A Loop length

The required loop length is determined by the number of connected loops, the speed and of the vehicles, the expected simultaneous vehicle arrivals at the loops and the communication type:

- VECOM-VETAG communication;
- VECOM-VECOM communication.

### VECOM-VETAG communication

- Duration VETAG message : 20 ms
- Duration loop interrogation (no vehicle) : 5.2 ms
- Number of anticipated VETAG Messages : 3

### Multiplexer configuration

- No synchronization;
- Each loop 1 x per cycle;
- Double VETAG interrogation.

The recommended minimum loop length in travel direction can be found in the following tables:

#### VETAG, 1 simultaneous vehicle arrival

	30 km/h	40 km/h	50 km/h	60 km/h	70 km/h	80 km/h	90 km/h	100 km/h
1 loop	1,2	1,6	1,9	2,3	2,6	3,0	3,3	3,7
2 loops	1,3	1,7	2,1	2,5	2,9	3,3	3,6	4,0
3 loops	1,5	1,9	2,3	2,7	3,1	3,5	4,0	4,4
4 loops	1,6	2,0	2,5	2,9	3,4	3,8	4,3	4,7
5 loops	1,7	2,1	2,6	3,1	3,6	4,1	4,6	5,1
6 loops	1,8	2,3	2,8	3,3	3,8	4,4	4,9	5,4
7 loops	1,9	2,4	3,0	3,5	4,1	4,6	5,2	5,8
8 loops	2,0	2,6	3,2	3,7	4,3	4,9	5,5	6,1

Table 28 VETAG, max 1 simultaneous arrival

**VETAG, 2 simultaneous vehicle arrivals**

	30 km/h	40 km/h	50 km/h	60 km/h	70 km/h	80 km/h	90 km/h	100 km/h
2 loops	1,7	2,1	2,6	3,1	3,6	4,1	4,6	5,1
3 loops	1,8	2,3	2,8	3,3	3,8	4,4	4,9	5,4
4 loops	1,9	2,4	3,0	3,5	4,1	4,6	5,2	5,8
5 loops	2,0	2,6	3,2	3,7	4,3	4,9	5,5	6,1
6 loops	2,1	2,7	3,3	4,0	4,6	5,2	5,8	6,5
7 loops	2,2	2,8	3,5	4,2	4,8	5,5	6,1	6,8
8 loops	2,3	3,0	3,7	4,4	5,1	5,8	6,5	7,1

Table 29 VETAG, max 2 simultaneous arrivals

**VETAG, 3 simultaneous vehicle arrivals**

	30 km/h	40 km/h	50 km/h	60 km/h	70 km/h	80 km/h	90 km/h	100 km/h
3 loops	2,1	2,7	3,3	4,0	4,6	5,2	5,8	6,5
4 loops	2,2	2,8	3,5	4,2	4,8	5,5	6,1	6,8
5 loops	2,3	3,0	3,7	4,4	5,1	5,8	6,5	7,1
6 loops	2,4	3,1	3,8	4,6	5,3	6,0	6,8	7,5
7 loops	2,5	3,3	4,0	4,8	5,5	6,3	7,1	7,8
8 loops	2,6	3,4	4,2	5,0	5,8	6,6	7,4	8,2

Table 30 VETAG, max 3 simultaneous arrivals

**VETAG, 4 simultaneous vehicle arrivals**

	30 km/h	40 km/h	50 km/h	60 km/h	70 km/h	80 km/h	90 km/h	100 km/h
4 loops	2,5	3,3	4,0	4,8	5,5	6,3	7,1	7,8
5 loops	2,6	3,4	4,2	5,0	5,8	6,6	7,4	8,2
6 loops	2,7	3,5	4,4	5,2	6,0	6,9	7,7	8,5
7 loops	2,8	3,7	4,5	5,4	6,3	7,1	8,0	8,9
8 loops	2,9	3,8	4,7	5,6	6,5	7,4	8,3	9,2

Table 31 VETAG, max 4 simultaneous arrivals

## VECOM-VECOM communication

- Duration VECOM message : 5.4 ms
- Duration loop interrogation (no vehicle) : 2.8 ms
- Number of anticipated VECOM messages : 3
- Additional calculated loop length : 0.5 m

## Conditions

- No synchronisation;
- Each loop 1 x per cycle;
- VECOM only.

The recommended minimum loop length in travel direction can be found in the following tables:

### VECOM only, 4 simultaneous vehicle arrivals

	30 km/h	40 km/h	50 km/h	60 km/h	70 km/h	80 km/h	90 km/h	100 km/h
1 loop	1,0	1,0	1,0	1,0	1,0	1,0	1,0	1,0
2 loops	1,0	1,0	1,0	1,0	1,0	1,1	1,2	1,3
3 loops	1,0	1,0	1,0	1,2	1,3	1,5	1,7	1,8
4 loops	1,0	1,1	1,3	1,5	1,7	1,9	2,2	2,4
5 loops	1,0	1,2	1,4	1,7	1,9	2,2	2,4	2,7
6 loops	1,0	1,3	1,6	1,9	2,1	2,4	2,7	3,0
7 loops	1,1	1,4	1,7	2,0	2,3	2,6	2,9	3,2
8 loops	1,2	1,5	1,9	2,2	2,5	2,9	3,2	3,5

Table 32 VECOM only

### VECOM only, 4 simultaneous vehicle arrivals, 1 data MSG of 32 bytes per vehicle

	30 km/h	40 km/h	50 km/h	60 km/h	70 km/h	80 km/h	90 km/h	100 km/h
1 loop	1,0	1,0	1,0	1,0	1,0	1,0	1,0	1,1
2 loops	1,0	1,0	1,1	1,3	1,4	1,6	1,8	2,0
3 loops	1,0	1,3	1,5	1,8	2,1	2,3	2,6	2,9
4 loops	1,3	1,6	2,0	2,3	2,7	3,0	3,4	3,8
5 loops	1,4	1,7	2,1	2,5	2,9	3,3	3,7	4,0
6 loops	1,4	1,9	2,3	2,7	3,1	3,5	3,9	4,3
7 loops	1,5	2,0	2,4	2,9	3,3	3,7	4,2	4,6
8 loops	1,6	2,1	2,6	3,0	3,5	4,0	4,5	4,9

Table 33 VECOM only, 1 data messages per vehicle





# 11 Appendix B Connector pin arrangements

## Sub-D connectors

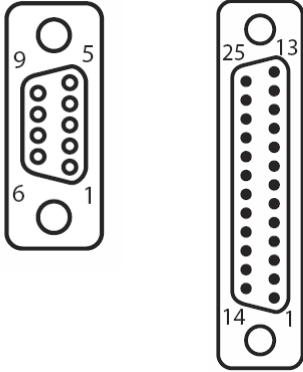

Figure 63 Pin arrangement of 9 and 25 pin Sub-D connector (cable side view)

## Combicon connector

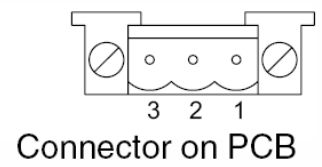
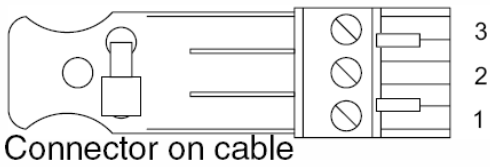

Figure 64 Three pin combicom connector

### Euro connector or Boxheader

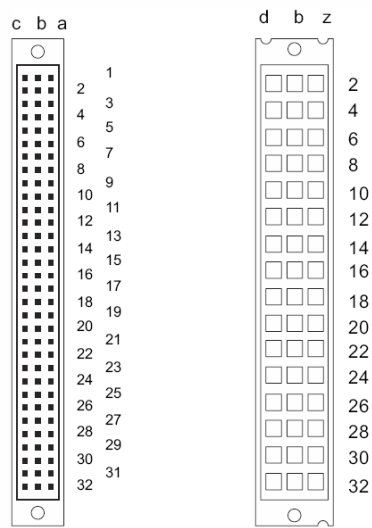
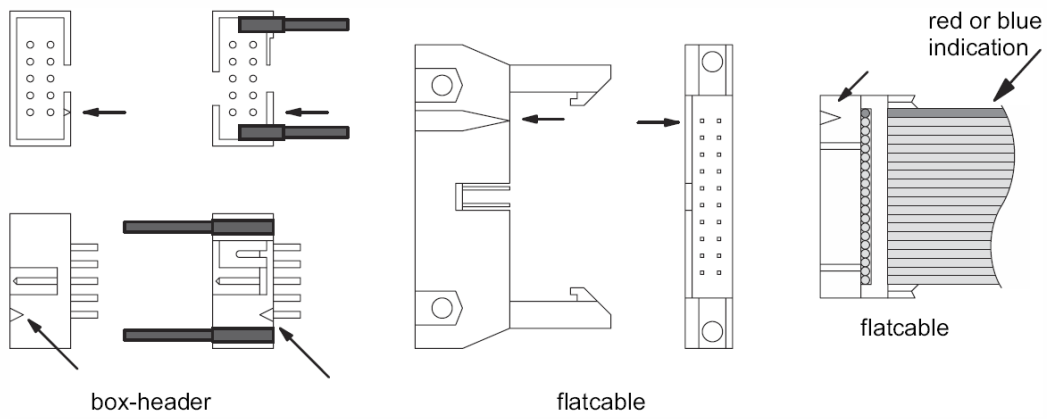

Figure 65 Pin arrangement of 10 96 pole euro/din-c/boxheader

## 12 Abbreviations

Abbreviation	Description
Peek	Peek Traffic B.V. Amersfoort, the Netherlands
VCM	VECOM Control Module
VMM	VECOM Modulator Module
VEM	VECOM Extension Module
PSU	Power supply unit
LB	Loop Buffer
LT	Loop Transceiver
LDP -T	Loop distribution panel -T
LDP/WS	Loop distribution panel/Wide Style
Cabinet	the frame housing
Rack	the module housing
I/O	Input / Output
WDMT	Windows Data Management Terminal
PCB	Printed Circuit Board
VECOM-C/CT	VECOM Compact
CDF	Cable Distribution Frame